

*Proceedings of the
3rd International Conference on Information Systems, Logistics and Supply Chain
Creating value through green supply chains
ILS 2010 – Casablanca (Morocco), April 14-16*

Reducing the environmental impacts of intermodal transportation: a multi-criteria analysis based on ELECTRE and AHP methods

Marie SAWADOGO¹, Didier ANCIAUX²

^{1,2}Université Paul Verlaine- Metz ({sawadogo, anciaux}@univ-metz.fr²)

Abstract: Nowadays, the impacts of transportation systems on the environment and the society are undeniable. Considering the great environmental awakenings at the planetary level and the discounted growth of the carriage of goods per transportation mode within the European Union, the distribution and haulage companies must start to take measures to limit their impacts. We aim to build a multi-criteria decision support system taking into account the economic, environmental and social criteria in order to help decision makers to choose among several alternatives paths, the “best” path in an intermodal system. Then we have to trade with many conflicting criteria; it’s then appropriate to use multi-criteria decision support system to find the best compromised solution. The route selection in a multimodal transportation network is therefore a multi-criteria decision making (MCDM) problem.

The goal of this paper is to show how a judicious choice of path and transportation mode in an intermodal transportation system can reduce the emissions of greenhouse gases and the energy consumption; in other words, how the route and transportations mode selections can help us to reduce the environment impacts. To this end, we built a decision support system based on AHP and ELECTRE methods. An analysis of the results is done in terms of the quantity of impacts reduced for each “best” choice through an application on a case of freight transport between Paris and Marseille.

Keywords: Supply chain, Environmental impacts, Intermodal transportation, Modeling, Multi-criteria decision making.

1 Introduction

The economic globalization and the emergence of new consumption behaviors have led to increased volume of goods transported and the traveled distances. In recent decades, the environmental effects of transportation became a topic of increasing importance around the world. Moreover, customers are making decisions to favor companies and products that are environmentally and socially responsible. As a result, studies have been conducted to increase our understanding of pollutant emissions along supply chain with their consequences in order to develop schemes for impacts reduction. In addition, researches have been conducted for the purpose of including sustainability in a general framework to guide logistics planning and to move towards modes with lower environmental impacts, such as rail and waterways.

The dilemma here is that all motorized modes serve us well, but at the same time harm the environment and local quality of life, albeit to varying degrees. Over the next few decades, reducing the emissions of air pollutants, noise and CO₂, as well as reducing the number of fatalities and impacts on biodiversity are issues that will require continuous attention. Consumption patterns may also need to be changed.

*Thus, intermodal transport and its impacts are recently received attention among transport planners and governments (Grenelle of environment in France, the Kyoto Protocol, and ISO 14000 ...). Logistic operators began to change the management of their supply chains, by incorporating environmental impacts in their decision making.

Therefore, the choice of an optimal path to move goods from an origin point O (production center or supplier warehouse), to a destination point F (distribution center or retailer warehouse), is intended to simultaneously optimize the cost, time, performance, and also to reduce the environmental and social impacts.

The purpose of this paper is to help decision makers (logistic operators for example) to choose a “good” path in a intermodal network, taking into account not only “economic cost” and “time” criteria, but also “environmental” and “social” criteria and thus to help in choosing among various alternatives, a path with the best compromise benefits / impacts.

* Corresponding Author. Address: Université Paul Verlaine, Ile du Saulcy, 57045 Metz Cedex 1, France. E-mail address: anciaux@univ-metz.fr.

After situating the framework of our study, we will define the essential concepts of the multi-criteria decision making process, and then the model is applied and followed by an analysis of the results on a case of freight transport between Paris and Marseille. Finally we will conclude and give the prospects for future works.

2 Intermodal transport and green supply chain

The logistical activities comprise freight transport, storage, inventory management, materials handling and all the related information processing. Logistics is the integrated management of all the activities required to move products through the supply chain. Green supply chain management recognizes the disproportionate environmental impact of supply chain processes in an organization. The definition and scope of green supply chain management in the literature has ranged from green purchasing to integrated green supply chain flowing from supplier to manufacturer to customer, and even reverse logistic. (Srivastava, 2007) defines the green supply chain management as “integrating environmental thinking into supply-chain management, including product design, material sourcing and selection, manufacturing processes, delivery of the final product to the consumers as well as end-of-life management of the product after its useful life”.

However, few studies deal with the reduction of impacts from the intermodal transport systems. In this paper, we specifically focus on reducing the impacts from the intermodal transportation systems

2.1 Environmental impacts of intermodal transport

Intermodal transportation is defined by the European Conference of Ministers of Transport (ECMT) as the carriage of goods by at least two different transportation modes in the same loading unit without stuffing or stripping operations when changing modes (Rondinelli et al., 2000). Intermodal transportation systems offer a wide choice of transportation mode and several alternative paths, hence the need for better coordination of flows and movements in such a system. During the last decade, numerous publications have focused on different aspects of intermodal transport problems, such as complementarities of the different transportation modes, changes in pricing policies in intermodal systems, management of flows between modes and the potential environmental impacts of such movements.

The transportation modes takes into account in our study are *road*, *air*, *water* and *rail*. Environmental issues concerning freight become more important nowadays since it is well known that the transport sector is the major sources of noise and numerous air pollutants.

Intermodal flows have several impacts on the environment and society. The emissions of gaseous pollutants and greenhouse gases as NO₂, CO₂, NO_x ... causes adverse health effects, damage to buildings and materials, effects on crops and agricultural production and impact on natural and semi-natural ecosystems (INFRAS 2005); this is why European Union directives limit exhaust emissions from new vehicles. There are also impacts on transport infrastructures such as damages on road constructions. To these impacts, must be added noise pollution, traffic congestion, social impacts like accidents and energy consumption. The energy consumed by transportation is estimated to be one-third of the entire energy consumed in the European Union.

Some of these impacts are represented in the impacts wheel presented in (Anciaux et al., 2007).

2.2 Model of integration of environmental impacts of intermodal transport

This section describes the mathematical details of the model supporting the proposed method which allows the calculation of internal and external costs along an intermodal path.

Many models have been suggested for integration of production and transportation; however, they aim mainly either at proposing the shortest path between the initial and the final terminals or at reducing the transportation costs while ensuring acceptable delivery time. Some of them propose an evaluation model for minimizing the cost routing for each shipment with respect to total transportation and inventory costs. Other researchers introduce an evolutionary algorithm for determining the optimal mix of transport alternatives to minimize total logistics costs. In some papers, they develop a model for calculating comparable combined internal and external costs of intermodal and road freight networks. Others still develop models of road and rail transport bases on the artificial intelligence and multi-agent, to choose the most economical path for order planning.

Regarding contributions to impact abatement, the introduction of *new technologies* and *transport concepts* such as alternative fuel, eco-driving, early morning-distribution system, vehicle utilization and avoidance of empty trips, environmental Management Systems (ISO 14000, ISO 14001) may offer reduced emissions per vehicle, or encourage switching to more environment-friendly modes. Another way of reducing environmental impacts is to persuade travelers to minimize the number of vehicle trips by switching to *non-motorized modes*.

Rondinelli et al., 2000) proposed an integrated “proactive environment management system” which seeks to prevent pollution and eliminate sources of environmental degradation of intermodal freight.

In addition to these methods we must add that an alternative to reduce environmental and social impacts is to choose a judicious path and transport mode for

shipments; this technique is increasingly studied in the literature. In this vein, (Qu et al., 2008) propose a hybrid multi-criteria decision making method based on Fuzzy AHP an Artificial Neuron Network for route selection in intermodal network taking into account the total transport time, the total cost, and the social benefit such as the effects to traffic congestion.

The problem here consists in transporting m tons of goods with a degree of fragility f , along a path k from an origin O to a final destination F . Each path k of the network is a possible alternative A (intermodal or not) and may consist of one or more branches i , with n branches by path and $n+1$ feasible transshipments as represented in figure 1.

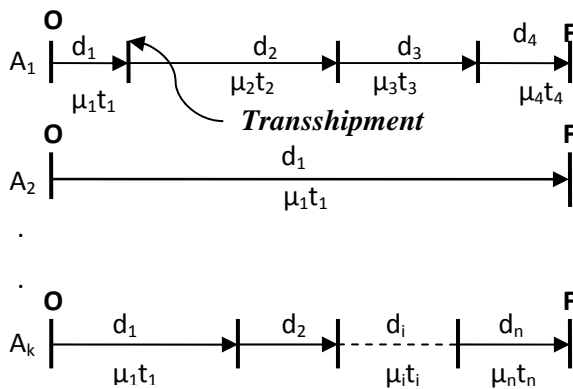

Figure 1: Intermodal Transport of m ton of goods with a degree of fragility f

In such a network, to move goods from O to F , we have k possible path; the question here is which path we must choose to optimize the environmental impacts and the cost of the overall network. To this end, a model has been developed to compute all the criteria took into account for this study. The main objective of this model was to calculate the data on the criteria that will serve as the basis for our analysis. The criteria retained for our study are the “cost”, the “time”, “pollution”, the “energy”, the “noise”, the “Transshipment”, the “damage” and the “accidents” respectively represented by C , T , P , E , B , θ , D and A ; details on the model are presented in (Sawadogo et al., 2009).

The modeling of an intermodal transport system in a green supply chain, is based mainly on studies conducted by IFEU (Knorr, 2005), and UNITE (Link et al., 2000). These studies include and evaluate the external costs of transportation system. Other models can be viewed in (Janic, 2007) and (Peeters, 2007).

The overall objective here is to find a compromised solution for all the above criteria, hence the need to use multi-criteria decision making methods to find the best compromised solution allowing economic development, environment preservation associated with a social development.

3 Multi-criteria decision support for intermodal transport

Multi-Criteria Decision Making is a well known branch of decision making. It is a branch of a general class of operations research models which deal with decision problems under the presence of a number of decision criteria. These methodologies share common characteristics of conflict among criteria, incomparable units, and difficulties in selection of alternatives.

Decision making in the intermodal transport system is complex because of the large amount of data about the transport mode and transshipments inter alia. Our analysis is based on AHP and ELECTRE methods in order to select among several alternative paths, the path and the sequence of means of transport to be used, taking into account economic criteria (cost, time), environmental criteria (pollution, noise), the criterion “energy” and the social criterion (accidents).

To make this analysis, we used three scenarios to mark out the problem. The first one is the industrial scenario where the criteria “cost” and “time” are the most important. The second one, called ecological or environmental scenario gives priority to the criterion “environment”. Finally we define a joint scenario that includes both first ones, called mixed scenario. The weights of the criteria are obtained by calculating the priorities according to these three scenarios. The global priorities of the criteria and sub-criteria are obtained by constructing the judgment matrix by pairwise comparisons, using the 1-9 scale of Saaty (Saaty, 1990) (Table 1).

Intensity of importance	Definition
1	Equal Importance
3	Moderate importance
5	Strong importance
7	Very strong
9	Extreme importance
2, 4, 6, 8	compromise values
1.1 to 1.9	If the activities are very close

Table 1: The fundamental scale of absolute numbers

The decision matrix contains the weight of the criteria sub-criteria resulting of a pairwise comparison of criteria according to each scenario (Ferreira Dutra et al., 2007) as presented in the table 2. The data in this table are used for both the AHP model for ELECTRE.

CRITERION	SCENARIOS		
	Industrial	Ecological	Mixed
C	0.4217	0.1229	0.2615
T	0.3715	0.1033	0.2571
θ	0.0766	0.0316	0.0727
D	0.0511	0.0211	0.0485
P	0.0101	0.4364	0.1257
E	0.0255	0.1875	0.1060
B	0.0024	0.0484	0.0298
A	0.0413	0.0488	0.0988

Table 2: Weight of criteria / sub-criteria (global priorities)

3.1 The AHP approach

The AHP method (Analytic Hierarchy Process) is a multi-criteria decision making tool developed by Thomas Saaty in 1980. The essence of the process is the decomposition of a complex problem into a hierarchy with goal (objective) at the top of the hierarchy, criterions and sub-criterions at levels and sub-levels of the hierarchy, and decision alternatives at the bottom of the hierarchy. It is based on a hierarchical decomposition of a problem and an aggregation of the solutions of all the sub-problems to have a solution

In our study, we will highlight the two aspects of the AHP method named Relative AHP and Absolute AHP.

3.1.1 Relative AHP

In this case, the structure of the decision problem for the choice of an intermodal transportation system for the transport of goods is given by the hierarchy of the Figure 2. The selected hierarchy is composed of four levels.

Indeed, the first step in the AHP method is to define a hierarchy to characterize and prioritize the criteria and sub-criteria.

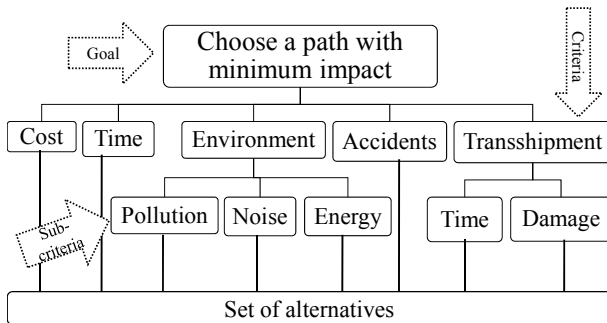

Figure 2: Relative AHP Hierarchy

In the decision making process, several criteria have to be evaluated and we should combine the various measures obtained.

To get a ranking of alternatives, AHP makes a complete aggregation. The final ranking is obtained according to two synthesis modes: the distributive mode and the ideal mode. (Bodin et al., 2003). After the aggregation of alternatives with the priorities, normalization is done to get the final ranking of alternatives.

3.1.2 Absolute AHP

In the case of Absolute AHP method, pair-wise comparisons are made in the entire hierarchy, with the exception of the level of alternatives. In the hierarchy, above the level of alternatives is associated with a level which represents different degrees of intensity (very good, good, average, bad, and very bad). The

alternatives are not compared with each other, but classified in a category in relation to each criterion / sub-criteria, absolutely. The alternatives are ranked in relation to benchmarks.

The hierarchy is shown in Figure 3. It's the same hierarchy as the previous one, except that we add the "degree of intensity" named "excellent", "good", "bad", "worst" to judge the quality of the alternatives.

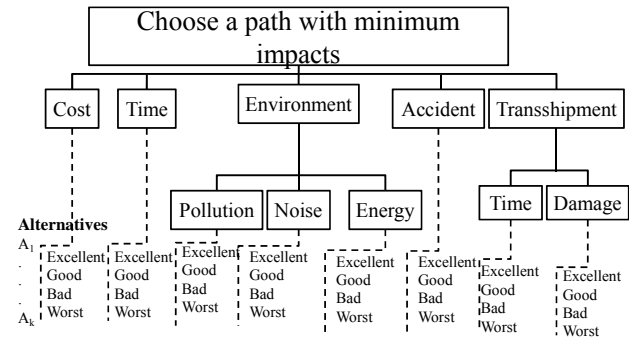

Figure 3 : Hierarchy for Absolute AHP

Threshold values are calculated to bound the degrees of intensity. The value of each criterion for each alternative are calculated and compared to the threshold values. Aggregation for Absolute AHP is done by multiplying the priority of each criterion / sub-criterion with the priority of the intensity with which the alternative is assigned. Storing values in descending order gives the classification of paths.

3.2 The ELECTRE approach

ELECTRE method was developed by Bernard Roy during the 70s and aims to build relationships called binary upgrade relations, to represent the preferences of decision-makers. It allows decision-makers to choose the best alternative among a set of alternatives.

The decision making with ELECTRE is based on pairwise comparison. ELECTRE has evolved into a family of methods based on different issues (ELECTRE I, II, III, IV, TRI...). In this study we will use ELECTRE TRI and ELECTRE III that are respectively part of the problem say β (sorting) and γ (ranking). You can refer to (Figueira et al., 2005) for more details on these methods.

3.2.1 ELECTRE TRI Method

The ELECTRE TRI method is the problematic β (assignment procedures); the problem is put in terms of allocation of each action (alternative) to a predefined category. ELECTRE TRI uses three kinds of input data: alternatives, criteria and reference profiles. We define four categories as shown in the following table.

Categories
C4 : Excellent
C3 : Good
C2 : Bad
C1 : Worst

Table 3: Sorting categories

Each category must be characterized by a lower and an upper reference profile; each reference is therefore limited to two categories, one upper and one lower. Three reference profiles are used to segment the criteria categories as shown in the Table 4.

Reference Profiles
b_3 : boundary between C_3 and C_4
b_2 : boundary between C_2 and C_3
b_1 : boundary between C_1 and C_2

Table 4 : Reference profiles of the categories

Modeling with ELECTRE TRI also needs to define some parameters to analyze the actions. According to each reference, and in relation to each criterion, we have two distinct sets of parameters: the importance coefficients, the indifference thresholds, the preference thresholds and veto thresholds.

To this, must be added that ELECTRE TRI method built outranking relationships so as to compare each alternative to each reference profile. To this end, we need to calculate the concordance, the conflict and outranking indices, as well as degree of credibility of each criterion for each alternative with regard to the scenarios defined above (Figueira et al., 2005).

Decision making process with ELECTRE TRI consists first in assessing the various criteria in relation to the reference profiles and assigns them to categories. Alternatives are then assigned to categories according to each scenario in two procedures, one called pessimistic (logic conjunctive) and the other optimistic (logic disjunctive logic) (Roy, 1994), (Figueira et al., 2005). These assignments are made using the outranking relations.

3.2.2 ELECTRE III

The ELECTRE III method is the problematic γ (ranking problematic) and its aim is to classify the actions from the "best" to "less good". The analysis parameters such as the performance matrix, criteria weights, and the indifference thresholds are defined along the same principles as for ELECTRE TRI. The difference is that here we compare these alternatives to each other, instead of compare them with reference profiles; a study of the relationship is made through ascending and descending distillation procedures. The outranking relation is obtained from varying the credibility degrees and a discrimination threshold.

The diagram in figure 3 represents a pattern of storage alternatives in which an arrow indicates the upgrade alternatives contained in a box over the box which is bound. Two alternatives are indifferent when contained

in the same box and indifferent when they are classified in different cases not linked by upgrade.

Depending on the desired scenario, the decision maker has to choose between many solutions ranging from the best to the worst.

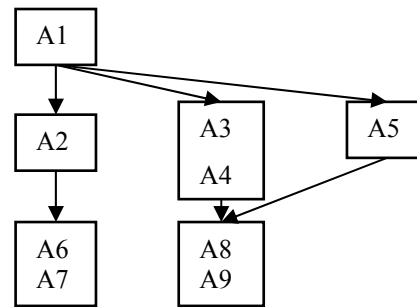

Figure 3: Example of outranking relationship by ELECTRE III (ranking of alternatives)

4 Implementation and results

For the purposes of the methods described, it is a problem of carrying 1000 tons of goods with a sensitivity of 1 (not very fragile goods) from Paris to Marseille, with a possibility of transshipment to Lyon. It takes into account 12 possible paths. These alternatives and the distances of each branch of a trip are explained in figure 4 and table 5. The costs and impacts are neglect during the transshipment of goods, here represented by dashed arrows.

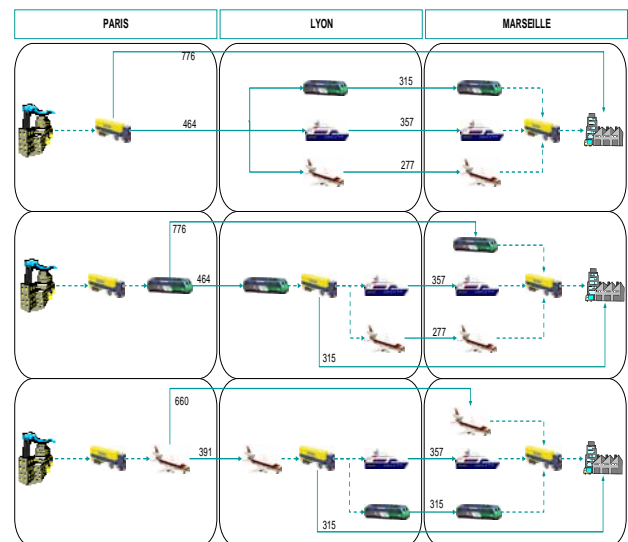

Figure 4 : Illustration of the intermodal network studied

Paths	Means of Transport	Distances (km)	Total (km)
A01	truck	776	776
A02	truck -Train	464-315	779
A03	truck -boat	464-357	821
A04	truck - aircraft	464-277	741
A05	Train	776	776
A06	Train- boat	464-357	821
A07	Train- aircraft	464-277	721
A08	Train- truck	464-315	779
A09	aircraft	660	660
A10	aircraft - boat	391-357	748
A11	aircraft-Train	391-315	706
A12	aircraft- truck	391-315	706

Table 5: Lengths of the paths in the network

4.1 Implementation of AHP model

4.1.1 Relative AHP

After having calculated the relative priorities for each criterion according to the alternatives and for each scenario, the aggregation of results gives us the results in the table 6.

Ranking using scale of SAATY					
Industriel		Ecologique		Mixte	
Distributive	Ideal	Distributive	Ideal	Distributive	Ideal
A05 (0,2106)	A05 (0,2008)	A05 (0,1730)	A05 (0,1634)	A05 (0,1872)	A05 (0,1752)
A09 (0,1843)	A09 (0,1754)	A06 (0,1368)	A06 (0,1374)	A09 (0,1461)	A06 (0,1285)
A06 (0,1182)	A06 (0,1176)	A08 (0,1079)	A08 (0,1187)	A06 (0,1239)	A09 (0,1209)
A11 (0,0808)	A11 (0,0814)	A02 (0,1006)	A02 (0,1113)	A11 (0,0742)	A01 (0,0790)
A07 (0,0788)	A07 (0,0798)	A01 (0,0969)	A01 (0,1056)	A07 (0,0734)	A08 (0,0783)
A12 (0,0565)	A01 (0,0620)	A03 (0,0909)	A03 (0,1024)	A01 (0,0709)	A02 (0,0730)
A01 (0,0553)	A12 (0,0536)	A09 (0,0733)	A09 (0,0537)	A08 (0,0687)	A07 (0,0725)
A08 (0,0493)	A08 (0,0519)	A07 (0,0531)	A07 (0,0494)	A02 (0,0638)	A11 (0,0722)
A04 (0,0459)	A10 (0,0497)	A11 (0,0509)	A11 (0,0465)	A03 (0,0517)	A03 (0,0633)
A02 (0,0457)	A02 (0,0484)	A10 (0,0407)	A10 (0,0409)	A10 (0,0493)	A10 (0,0558)
A10 (0,0441)	A04 (0,0445)	A12 (0,0382)	A04 (0,0361)	A12 (0,0487)	A12 (0,0424)
A03 (0,0305)	A03 (0,0349)	A04 (0,0376)	A12 (0,0347)	A04 (0,0422)	A04 (0,0388)

Table 6: Ranking of alternatives for each scenario with Relative AHP

Note that the alternative A05 (train) is the highest ranked for all the scenarios, according to the distributive mode and ideal mode, while the alternative A03 and A04 are the worst for the two modes.

4.1.2 Absolute AHP

Table 6 shows the ranking of alternatives after complete aggregation for the three scenarios analyzed. The alternative A05 (train) is again the best choice

Ranking		
Industrial	Ecological	Mixed
A05 (0,1297)	A05 (0,1246)	A05 (0,1264)
A09 (0,1024)	A06 (0,1118)	A06 (0,0939)
A07 (0,0983)	A08 (0,1079)	A07 (0,0929)
A11 (0,0970)	A02 (0,1054)	A08 (0,0919)
A08 (0,0840)	A01 (0,1054)	A01 (0,0886)
A06 (0,0838)	A03 (0,0956)	A02 (0,0880)
A02 (0,0825)	A07 (0,0813)	A09 (0,0859)
A01 (0,0816)	A11 (0,0601)	A11 (0,0846)
A12 (0,0713)	A04 (0,0554)	A04 (0,0648)
A04 (0,0708)	A09 (0,0512)	A12 (0,0646)
A10 (0,0566)	A12 (0,0509)	A03 (0,0610)
A03 (0,0421)	A10 (0,0503)	A10 (0,0576)

Table 6: Ranking of alternatives for each scenario with Absolute AHP

4.2 Implementation of the ELECTRE model

4.2.1 ELECTRE TRI

The sorting of alternatives in relation to reference categories as shown in Table 7 shows that the alternative A05 (train) is classified as excellent alternatives. A07 and A08 are good for all scenarios. For ecological scenario, alternatives A01, A02, A03, A06 can be selected in addition to the previous alternatives.

Categories	Industrial scenario	Ecological scenario	Mixed scenario
C ₄ : Excellent	A05	A05	A05
C ₃ : Good	A07, A08, A09, A11	A01, A02, A03, A06, A07, A08	A06, A07, A08, A11
C ₂ : Bad	A01, A02, A04, A06, A10, A12	A04, A10, A11, A12	A01, A02, A03, A04, A09, A10, A12
C ₁ : Worst	A03	A09	

Table 7: Final sorting of alternatives

4.2.2 ELECTRE III

The final ranking of alternatives according to the scenarios is given in the figure 6.

Industrial scenario

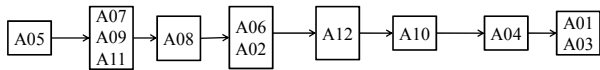

Ecological scenario

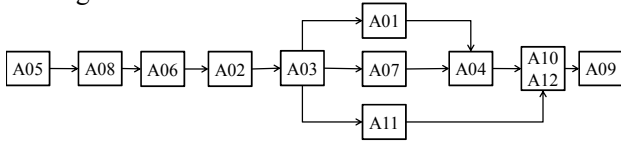

Mixed scenario

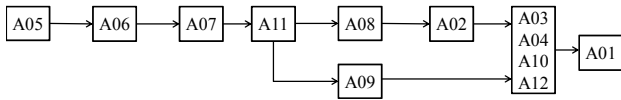

Figure 5: Final result for ELECTRE III

For all scenarios, the alternative A05 (train) is the highest ranked alternative and A09 is the worst for the ecological scenario.

5 Comparative analysis of results

The table below (Table 8) summarizes the results for the implementation of each method used in our model. The results include distributive and ideal mode of Relative AHP. The AHP approach provides an absolute scale, ideal priorities and absolute assessment. The method ELECTRE III makes storage of alternatives in priority

A global analysis of the Table 8 shows that the results are sensibly the same. Indeed, for the entire scenario and for all the methods, the alternatives A05 (train) is the best. This reflects a right choice of settings for different methods and consistency of operations used.

5.1 Global analysis

Now, let us consider only the ecological scenario; the aim here being to reduce the environmental impacts and energy consumption.

The curves below describe the evolution of selected solutions ranged from the best to the worst. These curves are obtained by calculating for each alternative, the CO₂ emissions, noise emitted and energy consumption obtained with the theoretical model and the data of the problem. A classification based on the results of each method gives the curves below figure 6 and figure 7.

A global analysis of the results obtained by applying each method for the ecological scenario gives us an idea of the evolution of emission by the alternatives from best to worst. Indeed, they show for example the quantity of CO₂ emitted with each alternative for each combination of transportation mode; for the first seven alternatives, the quantity of CO₂ is less than 1000 tons for all the methods.

Industrial						Ecological						Mixed								
AHP				ELECTRE		AHP				ELECTRE		AHP				ELECTRE				
Relative		Ideal		Abs.	III	Tri	Relatif		Abs.	III	Tri	Relative		Ideal		Abs.	III	Tri		
Distributive	Real	1-9	Real				1-9	Distributive				Real	1-9	Real	1-9				Real	1-9
5	5	5	5	5	5	5 ^{c4}	5	5	5	5	5	5 ^{c4}	5	5	5	5	5	5 ^{c4}		
9	9	9	9	9	7 ^I	7 ^{c3}	6	6	6	6	6	8	1 ^{c3}	9	9	9	6	6	6	6 ^{c3}
6	6	6	6	7	9 ^I	8 ^{c3}	8	8	8	8	8	6	2 ^{c3}	6	6	6	9	7	7	7 ^{c3}
11	11	11	11	11	11 ^I	9 ^{c3}	2	2	2	2	2	2	3 ^{c3}	11	11	1	1	8	11	8 ^{c3}
7	7	7	7	8	8	11 ^{c3}	1	1	1	1	1	3	6 ^{c3}	7	7	8	8	1	8 ^R	11 ^{c3}
1	12	1	1	6	6 ^I	1 ^{c2}	3	3	3	3	3	1 ^R	7 ^{c3}	1	1	2	2	2	2	1 ^{c2}
12	1	8	12	2	2 ^I	2 ^{c2}	9	9	9	9	7	7 ^R	8 ^{c3}	8	8	11	7	9	9 ^R	2 ^{c2}
8	8	12	8	1	12	4 ^{c2}	7	7	7	7	11	4	4 ^{c2}	2	2	7	11	11	3 ^I	3 ^{c2}
2	4	10	10	12	10	6 ^{c2}	11	11	11	11	4	11 ^R	10 ^{c2}	10	3	3	3	4	4 ^I	4 ^{c2}
4	2	2	2	4	4	10 ^{c2}	10	10	10	10	9	10 ^I	11 ^{c2}	3	10	10	10	12	10 ^I	9 ^{c2}
10	10	4	4	10	1 ^I	12 ^{c2}	4	12	4	4	12	12 ^I	12 ^{c2}	12	12	12	12	3	12 ^I	10 ^{c2}
3	3	3	3	3	3 ^I	3 ^{c1}	12	4	12	12	10	9	9 ^{c1}	4	4	4	4	10	1	12 ^{c2}

Table 8: Synthesis of results

order. Exhibitors "I" indicates an indifference relationship, and the exponent "R" incomparability between the same classes. The ELECTRE TRI method is an assignment of each alternative to a category. The digits represent the number corresponding to each alternative and the exponent indicates the category to which the alternative is affected.

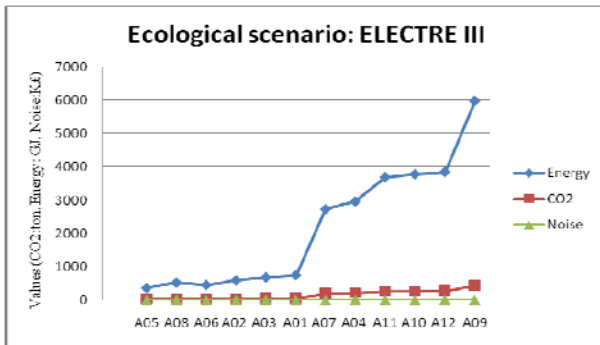

Figure 6 : Results for Ecological scenario with ELECTRE III

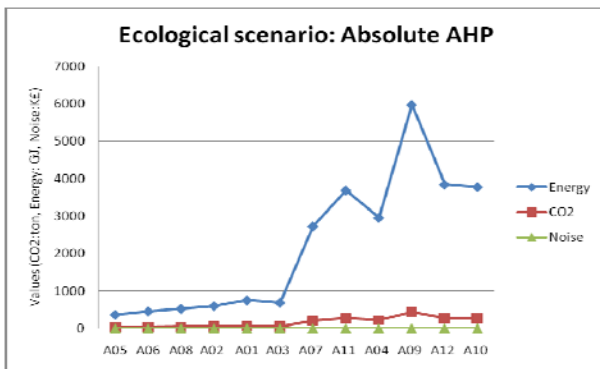

Figure 7 : Results for Ecological scenario with Absolute AHP

Our analysis shows the evolution of solutions for each method. These results confirm that the calculation results of different methods are consistent with the data of the problem.

These curve shows that the alternative A05 (train) emits a quantity of 27.16 tons as opposed to the alternative A09 (aircraft) for example who is responsible for 438.90 tons of CO₂; these results also confirm many international studies which demonstrate that the train is an environmentally friendly transportation mode.

5.2 Environmental impact reduction

For one whom wants to reduce his environmental impacts, by choosing alternative A05 instead of the others, tables below represent his winnings in terms of energy consumption, gases and noise emissions.

5.2.1 Energy reduction

The table below represents the reduction of energy consumption (expressed in GJ), by choosing the alternative A05 in place of the other alternatives.

Alternatives	A01	A02	A03	A04	A05	A06	A07	A08	A09	A10	A11	A12
A05	382,57	230	319	2589	0	90	2359,83	156,71	5607	3409,69	3321	3477

Table 9: Energy reduction

For example, if we choose A05 instead of A09 which is bad for ELECTRE method, we reduce our energy consumption by 5607 GJ.

5.2.2 CO₂ reduction

In the Table 10 are recorded the results for CO₂ emission. The emissions of each alternative are compared with the emissions for the alternative A05. Choosing A05 (train) instead of A12 for example permit to reduce CO₂ emissions by 255.22 tons.

Alternatives	A01	A02	A03	A04	A05	A06	A07	A08	A09	A10	A11	A12
A05	27,94	16,81	23,28	189,99	0	6,57	173,29	11,45	411,74	250,35	243,88	255,22

Table 10 : CO₂ reduction

5.2.3 Noise reduction

As for energy consumption and CO₂ reduction, we calculate the noise cost reduced comparing each alternative to the best result.

Alternatives	A01	A02	A03	A04	A05	A06	A07	A08	A09	A10	A11	A12
A05	3,26	1,96	0,95	3,42	0	-1,00	1,47	1,33	3,39	1,00	2,00	3,33

Table 11: Noise reduction

These results demonstrate that the wise choice of a path can contribute on reducing the environmental impacts of the overall intermodal network. The reduction of environmental impacts in transport systems then also requires a good choice of path and transportation mode.

6 Conclusion and current works

The economic climate and the environmental awareness are forcing companies to reconsider the organization of their supply chain, with the aim of favor transportation modes environmentally friendly and insure better coordination of flows to reduce environmental impacts. In this vein, the present paper aims to support the choice of sustainable transportation mode and path in an intermodal network.

The decision-making for the choice of an intermodal path within the green supply chain is a very complex problem requiring the consideration of several criteria. In this paper, we used AHP and ELECTRE methods, to help the decision-makers in the choice of an appropriate path to transport their goods.

This study highlights that logistics decision makers have to integrate the environmental concerns since the planning of their operations and particularly in the choice of the transportation mode used for shipments. The results given by these methods are almost similar with some differences in the solutions order. A sensitivity analysis could be performed to measure the influence of each parameter on the stability of the model.

AHP and ELECTRE methods can help us to achieve a good choice but they need to properly define a set of parameters for the methods, and define all the alternatives. Moreover, they are not efficient to resolve problems with a large amount of data and alternatives.

We intend to use “Multi-objective optimization” techniques, such as metaheuristics or evolutionary algorithms to find an optimal solution, in order to give an integrated decision support tool for decision makers in transport and logistics. We are now working on modeling other criteria and how to model our problem as a “Multiobjective Shortest Path Problem” by using graph theory.

7 References

- Anciaux, D. and Yuan, K. (2007). Green supply chain: Intermodal transportation modeling with environmental impacts. *in: ETC'07: Proceedings of European Transport Conference, Noorwukerhout, Netherlands, October 2007.*
- Bodin, L. and I. Gass Saul (2003). On teaching the analytic hierarchy process. *Computers & Operations Research*, Vol. 30, 1487–1497.
- Figueira, J., Mousseau V. and B. Roy (2005). ELECTRE methods. in J. Figueira, S. Greco, and M. Ehrgott, editors, “Multiple Criteria Decision Analysis: State of the Art Surveys”, vol. 78, *International Series in Operations Research & Management Science*, chapter 4, 133-162. Springer, New York.
- Janic, M. (2007). Modeling the full costs of an intermodal and road freight transport network. *Transportation Research Part D*, Vol. 12, 33-44.
- Knorr, W. (2005) .EcoTransIT: Environmental Methodology and Data. IFEU.
- Link, H., L. Stewart, M. Maibach, T. Sansom and J. Nellthorp (2000). The accounts approach, UNITE: Unification of accounts and marginal costs, for transport efficiency.
- La méthode Peeters, P., E. Szimba and M. Duijnsveld (2007). Major environmental impacts of European tourist transport. *Journal of Transport Geography*, Vol. 15, Issue 2, 83-93.
- Qu, L. and Chen, Y. (2008). A Hybrid MCDM Method for Route Selection of Multimodal Transportation Network”. *Part I, LNCS 5263*, 374 – 383.
- Rondinelli, D and M. Berry (2000). Multimodal Transportation, Logistics, and the Environment: Managing Interactions in a Global Economy. *European Management Journal*, Vol. 18, 398–410, 2000.
- Roy, B (1994). Aide multicritère à la décision: Méthodes et Cas. *Economica*, ISBN 2-7178-2473-1, 1994.
- Saaty, T (1990). How to make a decision: The Analytic Hierarchy Process, *European Journal of Operational Management*, Vol. 48, pp. 9-26, 1990.
- Saaty, T. L. (2008). Decision making with the analytic hierarchy process. *International Journal of Services Sciences*, Vol. 1, No.1.
- Sawadogo, M. and Anciaux, D. (2009). “Intermodal transportation within the green supply chain: An approach based on the ELECTRE method”, *Computers & Industrial Engineering (CIE)*. International Conference on Industrial Engineering, 6-9 July 2009, p.839 – 844.
- Srivastava, S. K. (2007). Green supply-chain management: A state-of the-art literature review. *International Journal of Management Reviews*, Vol. 9 Issue 1 pp. 53–80.