



Reliability in future electricity mixes: the question of distributed and renewables sources

Mathilde Drouineau^{1,0}, Nadia Maïzi¹, Edi Assoumou¹, Vincent Mazauric^{1,2}

¹ Mines Paristech, Centre for Applied Mathematics

² Schneider Electric, Innovation Dept.

September 2009, 10th IAEE European Conference

Abstract

Pushed by the need for carbon emission abatement and the expected depletion of fossil fuels, electricity generation is entering a period of significant change. At this point in time, the issue of integrating distributed and renewable energy sources puts a question mark over the future shape of the electricity industry. In this paper, we are interested in the level of reliability of future electricity mixes and whether or not these changes will impact the level of reliability. Consequently, we propose a methodology for assessing the reliability of power systems based on a number of aggregated physical properties. Finally, we exhibit "reliability indicators", which provide valuable comments on reliability using distributed and renewable energy sources. To sum up, changes in the electricity industry must be made carefully with respect to reliability requirements.

1 Introduction

Pushed by the need for carbon emission abatement and the expected depletion of fossil fuels, electricity generation is entering a period of significant change. These new constraints will shape the future electricity industry, i.e. over a long-term time horizon (typically a few decades). At present, two features of power systems are evolving:

- the generation share, with the integration of more renewable energy sources. For instance, we may consider the binding target of a 20% share of renewable energy by 2020 required by the spring 2007 European Energy Council.
- the architecture of power systems, with the development of distributed energy sources and the emergence of the smartgrid and microgrid concepts [1, 2].

In recent years, abundant highly optimistic scenarios have promoted one or both of these trends, and at the same time the question of their feasibility has arisen. In particular, long-term planning tools have emerged as essential tools for designing the future energy system subject to new environmental constraints. Energy modelers are interested in determining to what extent these new trends can be followed in the context of electricity.

⁰Corresponding author:

- address: Mines Paristech, Centre for Applied Mathematics, BP n° 207, 06904 Sophia Antipolis cedex, France
- e-mail address: mathilde.drouineau@mines-paristech.fr
- phone: +33 497 157 069
- fax: +33 497 157 066

Furthermore, there is a growing requirement from modern economies for high power quality and reliability. To put it simply, reliability can be defined as a power system's capability to handle load fluctuations. It relies on the technical properties of the whole production system, which are essential to prevent unexpected power outages. These properties are now essential constraints in power system design and must be assessed to determine the quality of future power supply. Up until now, the over-sizing of installed capacities had ensured a subsequent high level of reliability and assessing these properties has been less crucial.

Today, however, the integration of distributed and renewable energy sources in future mixes threatens their reliability. Eventually, additional electricity should be dedicated to maintaining the level of reliability, resulting from supplementary losses and investments. The cost induced by reliability must be compared with the benefits of these new trends for the electricity industry.

Therefore, reliability needs must be fully addressed and implemented in long-term energy planning tools, since otherwise planned energy systems may prove unfeasible, or at least sub-optimal.

In section 2, we present the weaknesses of long-term planning tools regarding the reliability of power supply. We then show the subsequent bias they can bring in future electricity mixes. In section 3, we present the central contribution of this paper: a methodology for assessing reliability needs in future electricity mixes in a synthetic way. This method is based on current technical issues of power system stability, which are adapted to the design of future electricity mixes. In section 4, we present the main results of our investigations: a series of indicators that measure the reliability of future electricity mixes. We also qualitatively discuss the case of distributed and renewable energy sources in the light of these indicators. Finally, in section 5 we provide some conclusive remarks.

2 Reliability requirements and long term planning tools

In this section, we start by defining which properties of power systems are behind reliability requirements. To do so, we investigate both the field of generation planning tools and the subsequent technical issues of reliable power supply. Then, we present the MARKAL/Times family of long-term planning models and show their weaknesses concerning reliability requirements. Finally, we focus on the bias that results in future electricity mixes when reliability requirements are ignored in planning tools.

2.1 Reliability requirements

2.1.1 In the generation planning tools

For several years, the reliability of power supply has been a major concern in power generation planning exercises, which are also long-term planning tools dedicated to the electricity industry. Before going any further, it is worth focusing on reliability description in these tools. The history of power generation planning can be divided into two major periods [3]: generation planning in monopolies, and generation planning in competitive markets.

In the first period, optimal long-term generation expansion planning was anticipated by determining the minimum-cost capacity addition plan for meeting the forecasted demand within a pre-specified reliability criterion over a planning horizon. At that time, production cost efficiency was driven with bigger plant sizes and consequently the electricity industry was very capitalistic and monopolistic. Moreover, there is a long tradition of capacity expansion models in both the power sector and in operations research literature.

In this literature [4, 5], the question of the reliability of power systems is widely dealt with. Loss of load probability (LOLP) and Expected Unserved Energy (EUE) are indices that have been used to evaluate the supply reliability of power systems, and they are still used in transmission planning [6].

Now that smaller installations are also economically justified, competition has become possible among power producers, leading to a deregulated, liberalized market. This change has drastically altered the nature of utility planning, and it would seem that less attention has been paid to the long-term efficiency of restructuring, especially in the area of investments in generation [3]. A good illustration is the California 2000-2001 power crisis, where the most important factor was presumably the shortage of supply relative to demand.

Nevertheless, the description of reliability needs in this literature is not well suited to current changes in electricity production. Basically, reliability assessment is based on historical or expected values of power outages or unserved energy within a year, and the LOLP estimates the probabilities of outages for a power system with hundreds of consumption scenarios.

In the following, we present the specificity of the electricity supply in order to define reliability requirements in power systems.

2.1.2 The subjacent technical issues

Electricity is a non-storable commodity. Therefore, electricity flows must comply with real-time adequacy between supply and demand, which can be derived from three subconstraints:

- **Energy flows:** This is adequacy in terms of energy exchanges.
- **Power capacities:** This subconstraint refers to dimensioning the park of electricity production. It ensures that there are enough capacities to provide power during the highest demand period, e.g. peak hours in winter.
- **Ancillary services:** The Federal Energy Regulatory Commission (FERC 1995) defined ancillary services as “those services necessary to support the transmission of electric power from seller to purchaser given the obligations to maintain reliable operations of the interconnected transmission system.” FERC identified six ancillary services: reactive power and voltage control, loss compensation, scheduling and dispatch, load following, system protection, and energy imbalance. Ancillary services prevent power outages and rely on the properties of the production units. Thus, reliability can be defined as the capability of a power system to handle load fluctuations.

Electrotechnicians have already assessed the reliability of power systems using power system stability studies [7]. This is a well-known topic of interest, which checks the real-time capability of a broad power system to maintain synchronism. It is widely used by transport system operators (TSOs) in power systems regulation.

Without going into further details, it should be borne in mind that these stability studies involve time scales ranging from a few milliseconds to a few hours, while long-term planning models deal with several years. This gap is the main reason why reliability requirements are often ignored, or in the best case, not accurately implemented in long-term planning models.

2.2 The MARKAL/Times family of models

Long-term planning models are essential tools for assessing the consequences of new constraints applied to the energy mix. They facilitate decision-making for politicians and major actors

in the energy field. Since the reliability of power supply depends on the physical properties of power systems, this work relies on an explicit representation of the technologies proposed by technological models. In the technical models, or bottom-up models, the representation of technologies is explicit and produced by disaggregating the energy sector. In such models, the demand is generally exogenous. Such an approach makes it possible to substitute different technologies and choose those that are most-suitable for meeting demand under a set of constraints.

The models of the MARKAL/Times family optimize energy systems in the long term with an explicit bottom-up approach through a description of individual technologies by explicit input-output relationships. The main decision variables are investments levels, activity levels and total installed capacities.

The energy sector is seen as a chain of transformations that goes from raw materials to final energy demand. A technology is described as an energy vector converter. Over the studied horizon, a group of time periods is defined, and the characteristics of the technologies can evolve from one period to another. In this way, we can describe any technological progress. When the technologies are fully informed and interconnected, the model builds a group of linear equations for each period, known as the system's energy equilibrium equations. The equations that bring the exogeneous demand are interpreted as the constraints through demand, rendering the models of the MARKAL/Times family "partial equilibrium models driven by demand".

MARKAL/Times models offer a detailed description for electricity production [8, 9]:

- In order to take into account production peaks and, more generally, variations in power demand, each period is split up into six time slices that correspond to the possible combinations between day and night, winter and summer and the intermediate seasons. Then, electricity demand is proportionally, or more subtly, distributed over these time slices. The flow equilibrium equations are published separately, enforcing the equilibria of electricity flows for each time slice.
- Therefore, the peak reserve constraints guarantee the setting-up of a supplementary capacity reserve in order to model the need for over-capacity during high demand periods. These constraints enable the model to correctly size the capacity levels to be installed (in MW). Each production technology is then affected to this reserve with a coefficient of participation, in order to differentiate between the kinds of production units.

These two features express the constraints on energy flows and power capacities characterizing power transmission. Reliability requirements are however ignored in this family of models.

Of course, long-term planning models are not supposed to rely on an accurate description of power systems management. However, the integration of distributed and renewable energy sources may modify the merit order of the generation units, subsequently impacting investment decisions on the model.

In the next subsection, we qualitatively present how forecasted electricity mixes are impacted when reliability issues are not addressed in long-term energy planning tools.

2.3 Subsequent bias in forecasted electricity mixes

Here, we define a new nomenclature of electricity losses, introducing reliability-induced losses. It shows a link between the desired level of reliability and additional losses in the system. These losses have a cost, which increases the total cost of the energy system. Furthermore, the losses call for additional investments in capacities, which also increase the cost of the energy

system. These two effects change the features of the optimal energy system, and for this reason reliability requirements should be implemented in the MARKAL/Times family of models. In particular, in the paragraph 2.3.3 we qualitatively discuss the variation of losses and subsequent additional investments regarding changes in power supply.

2.3.1 Electricity losses

The conveyance losses Conveyance losses are losses that occur during power transmission through the network. They mainly depend on whether or not the transmission grid is congested, on the voltage level, and network architecture. They can be assessed from the duration of peak, semi-base or base loads, relying on a steady state analysis. When production capacities are centralized, transmission occurs through longer distances, and conveyance losses may increase, despite the existence of high voltage lines. In fact, for a given geographical distribution of loads and generators, as the meshing of the grid increases, Joule losses decrease, the voltage profile improves and the system is more stable.

Reliability-induced losses Conversely, reliability-induced losses are linked to the desired level of reliability. This level depends both on the load of the grid and on the admissible load fluctuation. To deal with these fluctuations, the system relies on reactive power and kinetic reserve (i.e. automatic voltage and frequency adjustments) to recover a stable state, before any control action on active power can occur, requesting the spinning reserve. Reliability-induced losses are associated with the additional costs agreed on for both maintaining reactive power and investing in kinetic reserve capacities (e.g. weighing generation machines, flywheels). When production capacities are distributed on smaller and less hierarchically organized grids (e.g. decentralized), reactive power and kinetic reserve management is critical for ensuring a given reliability level: each grid relies on fewer generation capacities, without counting capacities from a large-scale system. Reliability-induced losses are related to the dynamic management of the system but can only be compressed with difficulty if the desired level of reliability remains constant.

The balance between conveying and reliability losses presumably depends on the electricity mix and on the network architecture following the curve of the figure 1. Conveyance losses are reduced when capacities are close to the loads and the reliability-induced losses, are required to handle dynamic management, and are reduced with centralized conventional plants.

2.3.2 The burden of electricity losses

We now present some figures to illustrate the burden of electricity losses. In European networks, average losses in transmission networks are between 1% and 2.6% and losses in distribution networks are between 2.3% and 11.8% [10]. The cost of these losses is even more impressive. For instance, in France in 2006, the cost of losses in the transmission network was estimated at 487 M€ and at 837 M€ in its distribution networks.

Considering the size of the French electricity industry in 2006 (111.6 GW), the cost of losses adds up to 11.85 2006 €/kW.

This figure is clearly an average value for losses, but it shows that electricity losses are of the same order as the forecasted operating costs of power plants (see table 1) and that they cannot be neglected.

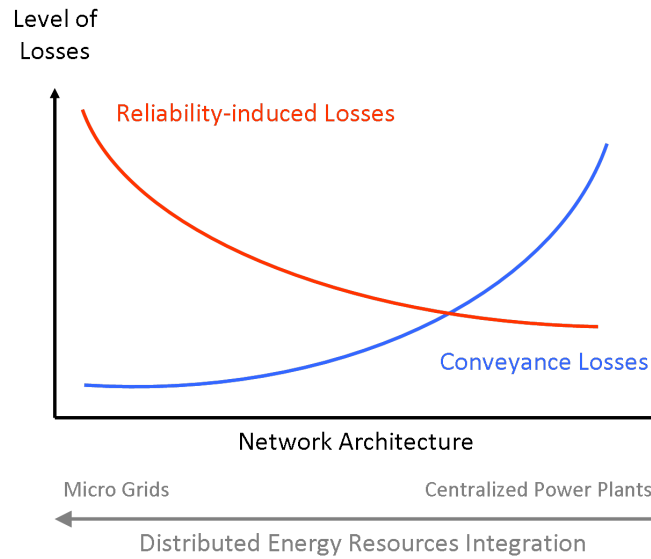

Figure 1: Qualitative level of losses versus network architecture. Electricity losses can be divided into conveyance losses, which occur during transmission and are lowered when capacities are close to the loads; and reliability-induced losses, which are required to handle dynamic management, lowered with centralised conventional plants. The latter affect the mix itself whereas the former are usually assessed for a given mix.

Power Plants	Operating costs (\$/kW in 2015)	Electricity losses (€/kW in 2006)
Supercritical coal-fired	40	12
Gas-fired CCGT	15	”
Nuclear	108	”
Wind onshore	40	”
Wind offshore	90	”
Solar PV	23	”

Table 1: Forecasted operating costs for different power plants in Europe in 2015 (Source: OECD/IEA, 2008), compared to the cost of losses for the French electricity industry in 2006.

2.3.3 Investments in additional capacities

Of course electricity losses are not ignored in long-term planning models. But they are forecasted as a fixed percentage of electricity consumption based on historical data. We have seen that mutations in the generation share and the network architecture are expected to change the global cost of the electricity system and to move the technically optimum energy system, regarding the cost of losses.

The plausible bias for future electricity mixes is to propose electricity systems that are not economically optimal regarding the cost of losses, or that have a poor quality of distributed power.

- In centralized architecture, generators' interconnections increase and provide a high level of reliability. These networks induce "electricity highways", which increase dissipative processes over the lines. It is worth noting that, in the history of centralized networks, centralized decision-making on investments has encouraged the over-sizing of production means, preventing these systems from tackling reliability issues.
- Now, with the development of distributed energy sources, power systems tend to be divided and smaller, thus decreasing losses during power transmission, but bringing into question the reliability of the system. To counterbalance the latter effect, investments in additional capacities or back-up reserves must be considered.

The balance between conveyance losses and reliability-induced losses should be made well known, so that strategic energy choices can be used to clearly arbitrate between losses over the network, the related additional investments, and other constraints binding the electricity mix.

3 Assessing reliability in future electricity mixes

This last remark emphasizes the need to take into account reliability requirements in long-term energy planning tools. We now present a methodology for assessing them. This relies on a technical point of view, and we first propose giving a brief overview of power system stability to introduce the main technical features of reliability needs.

3.1 Current regulation for power system stability

3.1.1 Load variations and frequency control

In any electric system, the power generated must be maintained in constant equilibrium with the power consumed / demanded, otherwise a power deviation occurs. Disturbances in this balance cause a deviation of the system frequency, which is initially offset by the kinetic energy of the rotating generating units and connected motors.

As electricity is very hard to store, the production system must have sufficient flexibility in changing its generation level. It must be able to instantly handle both changes in demand and outages in generation and or transmission.

Any imbalance results in a frequency change in the complete interconnected and synchronized network. When system frequencies are below 50 Hz (in European networks), it means that total demand was greater than total generation; at frequencies above 50 Hz, total demand was lower than total generation.

In response to a sudden imbalance, the primary control re-establishes the balance between demand and generation at a system frequency other than the frequency set-point value (50 Hz). It causes a deviation in power exchanges between control areas from the scheduled values.

The function of the secondary control is then to restore the system frequency to its set-point and restore the power exchanges between the control areas.

3.1.2 Voltage control and reactive power management

Voltage is a measured physical quantity, which fluctuates as a function of the network state, i.e. grid topology, generation, load, transmission lines and transformers. For network security reasons, i.e. compatibility with the rating of equipment, the supply of customers within the contractual ranges of voltage, plus the power system's voltage stability regarding disturbances, a voltage control is needed to maintain voltage deviations within predetermined ranges.

Voltage levels are maintained by reactive power, assured by different facilities: depending on their operational state, all generators, loads, lines and transformers are either reactive power consumers or producers. Reactive power cannot be transmitted over long distances efficiently, and voltage control is thus a regional problem.

Primary voltage control is implemented by the voltage regulators of generating units. These regulators initiate a variation in the excitation of generators, and reactive power is adjusted using automatic devices with a time response of less than a few seconds.

Secondary or tertiary voltage controls are implemented within a time period that can range up to several minutes, using either automatic control devices within a given zone of voltage control, or by the TSO's manual action to activate reactive compensation equipment.

3.2 The methodology for reliability evaluation

This methodology is based on a thermodynamic approach, which leads to a reversible assignment for power transactions [11] and demonstrates that electricity is the most efficient power conveyor. It comes down to a one-loop circuit (see figure 2), which lumps together the technical properties of a wide power system (namely its inertia constant and its inductive properties).

3.2.1 Using a thermodynamic framework

This framework has already been applied to describe electromagnetism laws and provides accurate results in this field, especially for finding Faraday's law. In this work, we apply the framework to power systems, where the number of connections is high, in order to avoid the exhaustive and time-consuming methods relying on the Kirchhoff laws.

The thermodynamic approach is also a global approach, which makes it possible to achieve an aggregated representation of the electricity industry and exhibits the main drivers of losses. In addition, it shows that electricity can achieve the best power transactions. A demonstration based on thermodynamic principles states that the system's evolution during energy transactions tends to be the most reversible. This is expressed in the reversibility condition, which exhibits the Joule losses and a term related to dynamic management.

With the thermodynamic approach, we focus on the properties of an electromagnetic field power conveyor. Electromechanical generators and motors exchange work through this field. The coupling energy between the field and the machines is also described. Finally, the coupling energy with the thermostat is introduced.

3.2.2 Working with a one-loop equivalent circuit

Thanks to the thermodynamic background, the description of power systems is reduced to their upper scale and comes down to a one-loop equivalent circuit presented in the figure 2. This system is described by a mechanical equation (1) and an electrical equation (2).

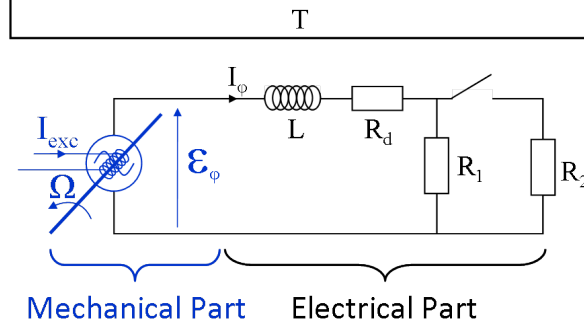

Figure 2: The One-loop Grid, a circuit equivalent for a wide power system. One-phase φ representation. The mechanical part represents the generators. In the electrical part, the impedances gather the inductive and resistive properties of the loads, the generation capacities and the transmission capacities of the system. R_1 models the load and connecting R_2 models a load fluctuation. T is the thermostat.

$$\frac{d}{dt} \left(\frac{J\Omega(t)^2}{2} \right) = P_{\text{mech}} - \sum_{\varphi} \varepsilon_{\varphi}(t) I_{\varphi}(t) \quad (1)$$

$$\varepsilon_{\varphi}(t) = L \frac{dI_{\varphi}(t)}{dt} + (R_d + R_1) I_{\varphi}(t) \quad (2)$$

The mechanical equation (1) describes the energy conservation in the generator. It rules the angular velocity Ω , where J is the generator's moment of inertia; P_{mech} is the power provided by the generator and $\sum_{\varphi} \varepsilon_{\varphi}(t) I_{\varphi}(t)$ is the power provided to the electrical system. The variation of Ω obeys the frequency variations described in paragraph 3.1.1.

The electrical equation (2) rules the voltage drops in the grid (at Very High Voltage), i.e. the current $I_{\varphi}(t)$ in the grid, where $\varepsilon_{\varphi}(t)$ is the voltage provided by the generator; L represents the inductive properties of the grid and $L \frac{dI_{\varphi}(t)}{dt}$ the subsequent voltage drop; $R_1 I_{\varphi}(t)$ is the load (or consumer) voltage; R_d represents the resistance of the lines. The inductive properties L participate in maintaining the reactive power described in the paragraph 3.1.2.

From these equations, achieving the best transaction between the generator and the load points to an optimization problem (3) expressing simultaneously the minimization of the Joule losses and the dynamic management term. These two are related respectively to the conveyance losses and the reliability-induced losses.

$$\min \left(\underbrace{R_d I_{\varphi}^2(t)}_{\text{Power Transmission}} + \underbrace{\frac{d}{dt} \left(\frac{L I_{\varphi}^2(t)}{2} + \frac{J \Omega(t)^2}{2} \right)}_{\text{Dynamic Management}} \right) \quad (3)$$

In fact, frequency and voltage variations are bound by the contractual and stability limits presented in paragraphs 3.1.1 and 3.1.2. These constraints shape the feasible space for reliable electricity mixes with (3).

Using this methodology, the dynamic behavior of wide power systems can be deduced from their aggregated properties, using the one-loop equivalent circuit. To check whether or not the power system can be operated in reliable conditions, we compare the dynamic behavior of the one-loop circuit with the stability limits. In the next section, we present the relevant indicators of power systems exhibited with this methodology.

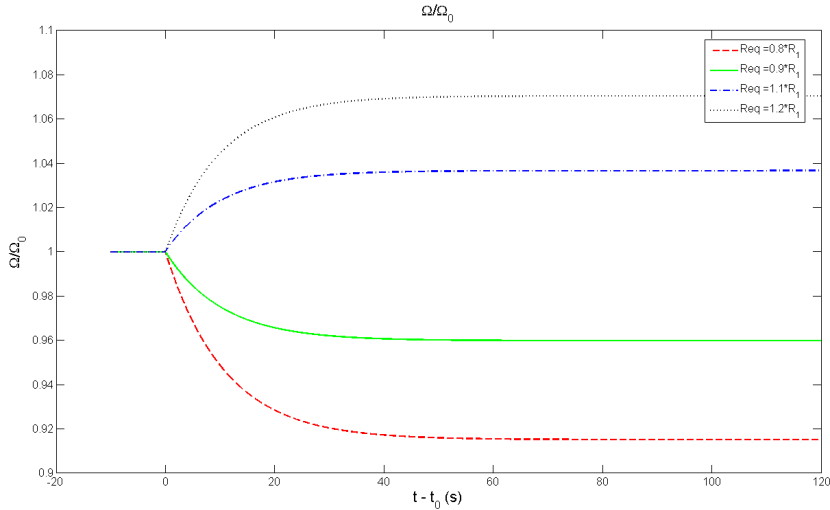

Figure 3: Frequency variations for different amplitudes of load fluctuation in the one-loop grid.

4 Consequences for future electricity mixes

The relevant properties of power systems which contribute to their dynamic stability are related to the frequency deviations, the voltage deviations and the synchronism. They are respectively related to the following physical properties (the “reliability indicators”): the kinetic energy storage, the reactive power and the power angle of the generators. In this section, we present the constraints on these indicators, related to the dynamic management.

Then, we present the evolution of the reliability indicators with respect to the development of distributed power units and the integration of renewable energy sources. In both cases, the reliability indicators tend to move away from the zone of “reliable operations”. They reveal that changes in the electricity industry must be made with caution.

4.1 Indicators for reliability in future power systems

4.1.1 Frequency variations and mechanical inertia of the system

The results concerning frequency variations can be divided into three main contributions:

- First, solving equation (1) gives a relaxation time constant τ_{mech} (4) characterizing frequency, i.e. Ω , variations¹. τ_{mech} depends on the inertia J of the machines, the set-point value of frequency (i.e. Ω_0) and the mechanical power P_{mech} the machine provides to the system. τ_{mech} is related to the kinetic energy stored in the generators.

$$\tau_{\text{mech}} = \frac{J\Omega_0^2}{P_{\text{mech}}} \quad (4)$$

For a simple model with one generator, simulations gave τ_{mech} equals to 16 s.

Also important in power stability is the kinetic energy stored in the system. If a system has a large amount of kinetic energy, then only a minor adjustment to speed is necessary to

¹Interestingly, this constant τ_{mech} exhibited from the one-loop circuit, is similar to the inertia constant H defined by electrotechnicians, also expressed in seconds. H represents the magnitude of the stored kinetic energy and is an important factor in the determination of machine dynamic performance and stability.

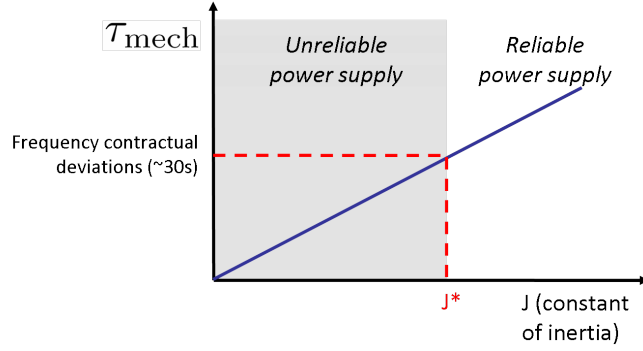

Figure 4: For a given set of P_{mech} and Ω_0 , an inertia constant J^* defines a limit between reliable and unreliable power supply. This curve is purely conceptual.

account for the power difference, whereas for a system with lower kinetic energy, a greater speed variation is required to account for the same difference in power. The kinetic energy stored, $\frac{1}{2}J\Omega_0^2$, explicitly depends on J .

- Besides, the resolution of equations (1) and (2) shows frequency or angular velocity variations in accordance with the dynamic properties of power systems. The curves of the figure 3 are obtained when we model a load fluctuation in the one-loop equivalent circuit (figure 2). Load fluctuations are modeled when virtually connecting R_2 to the grid or modifying the value of R_1 .
- Finally, frequency deviations are bound for both stability and contractual reasons. The variation margins are ± 0.5 Hz and the delay between fluctuation and adjustment is around 30s [12]. Knowing the set-point value of frequency and the nominal power of the system, the latter values define a lower limit for the inertia J , above which the system is vulnerable to load imbalances. It is possible to determine a certain value of inertia J^* , which draws a limit between reliable and unreliable electricity mixes (figure 4).

4.1.2 Voltage variations and inductive properties of the system

Voltage variation margins are $\pm 5\%$ and the reaction time is around a second [12].

The inductive properties expressed in the inductance L^1 of the generators, motors, transformers and lines, refers to the magnetic energy storage. It influences their behavior as reactive power consumers or providers and their contribution in maintaining voltage levels.

Solving equation (2) also provides a relaxation time constant τ_{elec} :

$$\tau_{\text{elec}} = \frac{L}{R_1} \quad (5)$$

Under the same hypotheses used for τ_{mech} , τ_{elec} is evaluated at 14 ms.

Similarly to the kinetic energy storage, the magnetic energy storage, $\frac{3}{2}LI_\varphi^2$, or the related level of reactive power available is crucial to the dynamic management.

Unfortunately, the magnetic energy storage is hard to model and we have encountered difficulties with the dynamic behavior of voltage variations. These difficulties are mainly due to the complexity of magnetic interactions between the fields within the machines. The value of L changes during transient and even subtransient regimes and is consequently hard to pinpoint. However, we expect to find the qualitative variations of τ_{elec} with L presented in the figure 5).

¹or in the reactance X

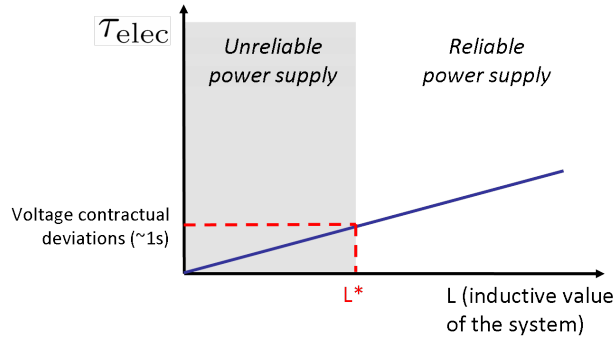

Figure 5: Qualitative variations of τ_{elec} with L . The main difficulty remains in assessing correctly L for a given power systems.

4.1.3 Synchronism and power angle of the machines

Another important issue with power system stability is the synchronism of the interconnected machines. This property is related to the power angle δ . The power angle is a physical measure of the difference between the two magnetic fields of the machines. The power provided by the machine depends on the value of this angle.

Power system stability is achieved for values of δ between $\pm 90^\circ$. This constraint gives an additional criterion for checking the feasibility of future electricity mixes. Such a criterion can be found with transient stability studies.

These indicators especially underline the need for proper values for J and L in reliable future electricity mixes, respectively related to kinetic reserve and reactive power management. In the next subsection, we discuss the evolution of these quantities with regards to emerging energy sources: distributed power units and renewable energy sources.

4.2 The case of distributed power units

Trends emerging in the power system suggest that the centralized paradigm may be replaced by an alternative one in which control is more dispersed. The development of distributed power units has become possible with their increased cost efficiency and it provides an alternative to investments in expensive conventional power plants.

The existence of dispersed energy sources that exercise some autonomy, possibly grouped into microgrids, may change the nature of the grid itself. Currently, the development of microgrid technologies is an active area of research in several countries.

There is also increasing interest in the concept of intelligent power systems, known as smart-grids, along with aggregators that control the flexibility of consumption for a set of end-users. These two effects contribute to flattening the load curve, and also to lowering the capacity constraint in the future electricity industry, thus encouraging the development of microgrids and smartgrids.

With the development of distributed power units, presumably close to sensitive consumers, the idea of an homogeneous quality of service is replaced by the idea of a heterogeneous quality of service tailored to the requirements of classes of end-uses. For instance, a pyramid of heterogeneous quality of supply end-uses is built accordingly to their power quality and reliability requirements [2].

With distributed power units and on-site production, the number of interconnections between power units decreases and leads to three main causes of dissatisfaction with the reliability

Generating unit	H (s)
Thermal unit	
(a) 3600 r/min (2-pole)	2.5 to 6
(b) 1800 r/min (4-pole)	4 to 10
Hydraulic unit	2.0 to 4.0
Wind unit	3
Tidal energy unit	0.9

Table 2: Inertia constant (H) values for conventional and renewable power plants issued from [14]. $H = \frac{\tau_{\text{mech}}}{2}$. There is no inertia constant for photovoltaics.

requirements:

- When power systems tend to be divided and smaller, it is not possible to benefit from the dispersion of energy sources, which can lower the development of intermittent energy sources. For instance, the development of wind farms in France is partly based on the lack of correlation between wind production around the Channel and the Mediterranean see [13], and even more so, on wind power's integration into a wide system with other predictable energy sources.
- In relation with the previous section, imbalances and disturbances in smaller grids have to be compensated for, both locally and immediately. In this case, the system only relies on a few other power units, which must store enough kinetic energy and reactive power to compensate the power imbalance. Thus, in smaller and weakly interconnected systems, the average value of energy stored by installed kW and investments in back-up generation capacities must increase.
- Finally, the time constants τ_{mech} and τ_{elec} must stay high enough to ensure reliable dynamic management in future electricity mixes, since the margins for deviations have not changed.

4.3 The case of renewable energy sources

With the integration of renewable energy sources, it is crucial to assess their contribution to dynamic management in comparison to conventional sources. In fact, with conventional synchronous generators, kinetic energy exchange is immediately reflected by a change in the system frequency. However, most renewable energy sources do not use synchronous generators and cannot participate in dynamic management with the same efficiency.

In the table 2, we present the values of the inertia constant H – proportional to τ_{mech} – for different power plants [14]. It shows that power plants do not participate equally in kinetic energy storage², and thus in the dynamic management.

Wind or tidal power units can store less kinetic energy than thermal units, suggesting that renewable energy sources lower the reliability of power supply. Integrating renewable energy sources in electricity mixes should be done carefully.

²The greater H , the more kinetic energy is stored by kW of installed power plants.

5 Conclusion

In the section 2, we have stressed the need to take reliability requirements into account when designing future electricity mixes and energy systems. Constraints on the level of reliability induce additional losses and investments in forecasted energy systems. They consequently increase the global cost of the energy system, which may be sub-optimal regarding these new constraints.

Ultimately, we have qualitatively shown that, given the emerging trend for electricity production, reliability requirements are even more crucial than they were during the period of over-sizing in production capacities.

We proposed in the section 3 a methodology for assessing the level of reliability of future electricity mixes. This methodology is based on the technical properties involved in dynamic management of power systems and has exhibited “reliability indicators” introduced in the section 4. These indicators are related to the dynamic management of power systems. They reveal that the integration of distributed and renewable energy sources tends to lower the reliability of power systems, showing that changes in the electricity industry should be made with caution.

This last remark underlines the need to implement these indicators in long-term planning tools, in order to design plausible – i.e. reliable – options for future electricity mixes. We consider linking this methodology with the MARKAL/Times family of models. Interestingly, small island grids with few interconnections exacerbate the reliability constraints and could be the first case study.

Acknowledgment

This research was supported by the Chair Modeling for sustainable development, driven by MINES ParisTech, Ecole des Ponts ParisTech, AgroParisTech, and ParisTech; and supported by ADEME, EDF, RENAULT, SCHNEIDER ELECTRIC and TOTAL.

References

- [1] O. Siddiqui, “The green grid: Energy savings and carbon emissions reductions enabled by a smart grid.” Electrical Power Research Institute, Palo Alto, CA, Tech. Rep. 1016905, June 2008.
- [2] C. Marnay, R. Firestone, J. Lai, and G. Venkataramanan, “Microgrids for commercial building combined heat and power and heterogeneous power quality and reliability,” Ernest Orlando Lawrence Berkely National Laboratory, Tech. Rep. LBNL-63520, October 2007.
- [3] A. G. Kagiannas, D. T. Askounis, and J. Psarras, “Power generation planning: a survey from monopoly to competition,” *Electrical power & energy systems*, vol. 26, pp. 413–421, 2004.
- [4] R. E. Brown and M. Marshall, “Budget constrained planning to optimize power system reliability,” *IEEE Transactions on Power Systems*, vol. 15, no. 2, pp. 887–892, May 2000.
- [5] M. Flynn, W. P. Sheridan, J. D. Dillon, and M. J. O’Malley, “Reliability and reserve in competitive electricity market scheduling,” *IEEE Transactions on power systems*, vol. 16, pp. 78–87, 2001.
- [6] K. Furusawa, K. Okada, and H. Asano, “A method of evaluating transmission network expansion plan considering security constraints and supply reliability index,” in *IEEE - PES Power System Conference and Exhibition*, Seattle, March 2009, pp. 1–5.
- [7] A. R. Bergen and V. Vittal, *Power System Analysis - 2nd Edition*. Prentice-Hall Series, 2000.
- [8] R. Loulou, U. Remne, A. Kanudia, A. Lehtila, and G. Goldstein, *Documentation for the TIMES Model - Part I*, Energy Technology Systems Analysis Programme, April 2005.
- [9] N. Maïzi, E. Assoumou, M. Bordier, G. Guerassimoff, and V. Mazauric, “Key features of the electricity production sector through long-term planning: the french case,” in *IEEE - PES Power System Conference and Exhibition*, Atlanta, GA, USA, 2006, p. 54.
- [10] “Treatment of losses by network operators. ERGEG position paper for public consultation.” European Regulators’ Group for Electricity and Gas (ERGEG), Tech. Rep., 2008.
- [11] V. Mazauric, “From thermostatics to maxwell’s equations: a variational approach of electromagnetism,” *IEEE Transactions on Magnetics*, vol. 40, pp. 945–948, 2004.
- [12] “Mémento de la sûreté du système électrique (in French),” Réseau de Transport d’Electricité, Tech. Rep., 2004.
- [13] RTE, “Bilan prévisionnel de l’équilibre offre-demande d’électricité en france (in French),” RTE, Tech. Rep., 2007.
- [14] A. Mullane, G. Bryans, and M. O’Malley, “Kinetic energy and frequency response comparisons for renewable generation systems,” in *2005 International Conference on Future Power Systems*, IEEE, Ed., 2005, p. 6.