

Environmental Evaluation of Machine-to-Machine Services: the case of Glass Waste Collection

Trang Hoang^{1,2}, Alan Lelah², Fabrice Mathieux², Daniel Brissaud², Vincent Gimeno¹

¹ Orange Labs, 28 Chemin du Vieux Chêne, 38240 Meylan, France

² University of Grenoble, G-SCOP Laboratory, 46, avenue Félix Viallet, 38031 Grenoble Cedex 1, France
fabrice.mathieux@g-scop.inpg.fr

Abstract

Product-Service Systems (PSS) based on Machine-to-Machine (M2M) technologies show high potential to help solve environmental issues. Such technologies resort to electronic equipment and telecommunication infrastructures.

This paper presents a methodology for assessing environmental impacts of M2M PSS, and a case study of Glass Waste Collection. Life Cycle Analysis (LCA) has been performed taking into account the complete M2M infrastructure, starting from electronic sensors through gateways to the telecommunication network and service platform and down to the end user. Results are compared with traditional glass collection and can provide insight for design choices in the M2M service.

Keywords:

Life Cycle Analysis, Machine-To-Machine service

1 INTRODUCTION

Today, Information and Communication Technologies (ICT) play a key role in our lives and the number of users is growing. Perception of its scope is broadening at the same time. Telecommunications not only mean people communicating with one another, but also include the machines around us. Machines can "contact" one another through the network. This is called Machine-To-Machine (M2M) Communication. It covers a large number of machines throughout the world, from home appliances to industrial machines. M2M systems allow machines to communicate with one another, or systems to monitor machines and, in this way, help them accomplish their tasks. With M2M, machines can not only "sense" information from the physical world (machine as a sensor of temperature, pressure, humidity, ...) but also take action based on information received (machine as a controller or an actuator in traffic lights, air conditioners, switches, ...) Lawton [1] clearly reviewed the growth of M2M systems and their great potentials resulting from the networking of a growing number of machines. In our understanding, M2M systems can be assimilated to Product-Service Systems (PSS): M2M networks together equipments, considered as a system of products that deliver values in the form of new services.

Despite M2M's promising growth, the technology used in M2M systems still faces several significant challenges in terms of wireless technology, communication protocol, energy consumption, etc. Beside these technological challenges, sustainable development has to be considered. Deployment of such systems must take account of environmental impacts during their full life cycle. Life-Cycle Analysis (LCA) can be used to evaluate these environmental impacts for a product or a system.

For ICT services, too, LCA has been used. However, analysis is generally incomplete, and does not always consider all the aspects from electronic devices and other components to ICT infrastructure and service deployment. This paper presents a new, complete methodology for applying LCA to M2M services.

This paper presents an overview of methodology in section 2 that includes a literature review of LCA for ICT services, as well as the proposed methodology. Section 3 presents a case study that is one example of an M2M based PSS. The next section shows the results of the case study. These results are discussed and used to validate our methodology. The last section is the conclusion.

2 OVERVIEW OF METHODOLOGY

2.1 LCA methodology for service: literature analysis

It is shown in literature that LCA is a useful, powerful tool to evaluate the environmental impacts of a product [2-4]. Furthermore, LCA has also been used for ICT services [5-9]. For example, in 2001, Taiariol [5] presents the impact on Energy for centralized and home answering machine systems in Italy. The impact of the Internet structure used in the University of Switzerland were analysed in 2003, based on Global Warming Potential (GWP) indicator [6]. In 2004, the impact of a video conference was analyzed by summing individual impacts of elementary devices necessary to provide the service [7]. It was compared with the alternative scenario of face-to-face meetings taking into account transport for the participants. However, in this study, only the GWP indicator was used. The same method was also applied in the case of E-paper that compared the GWP indicators for printed, web-based and e-paper newspapers [8]. Most studies use only one indicator, either energy consumption or GWP indicator emissions. A study on an intelligent lightning system, done adopted a multi-criteria approach using indicators of Acidification, Ecotoxicity, Eutrophication, Fossil fuel depletion, Global warming, Carcinogenicity, Non-carcinogenicity, Ozone-depletion and Photochemical smog [9]. Most of the studies presented comparisons with alternative scenarios.

One common point of these studies is that in order to use LCA methodology, they divide the service into elementary parts. In this way, LCA is first applied to individual electronic equipments and the result for the complete service is obtained by summing up individual impacts. None of these studies take account of the infrastructure of the service; neither do they clearly explain why they do not. The analysis of these case-studies is summarised in Table 1.

Service / Application, Date	Environmental criteria	Comparison with an alternative scenario?	ICT infrastructure considered?
Centralized and home answering Machine systems, Italy [5], 2001	Energy consumption	Yes: Centralised vs. Home	No
Internet structure in a university, Switzerland [6], 2003	Global warming	No	No
Video conference in Japan [7], 2004	Global warming	Yes: Conventional conference (transport)	No
E-paper [8], 2007	Global warming	Yes: Printed newspaper, web-services	No
Intelligent Lighting System [9], 2004	Multi-criteria: Acidification, Ecotoxicity, Eutrophication, Fossil fuel depletion, Global warming, Carcinogenicity, Non-carcinogenicity, Ozone-depletion, Photochemical smog	Yes: Traditional lighting system	No
Energy consumption of ICT in France [11], 2008	Energy consumption	No	Yes

Table 1: LCA Literature review for service

ICT energy consumption is big: one seventh of global electrical consumption is estimated to be necessary for ICT use phases in 2020 [10]. Souchon [11] studied the energy consumption of ICTs in France. This work takes into account the telecommunication infrastructure, including the energy necessary to send data via the network, the energy for network operation and the energy to run the data centres, buildings, and other facilities. Using telephones with different technologies was also studied. The results (Table 2) show that energy used by the infrastructure is greater than the devices themselves and must not be ignored. For instance, when considering a mobile phone with an optimized mobile charger, the network can count for up to 75% of total energy.

	Communication technology		
	GSM (optimized charger)	GSM	Stationary phone
2 telephones	25%	49%	39%
Network Infrastructure	75%	51%	61%

Table 2: Energy share: telephones and network [11].

For M2M services, we did not identify any study taking into account the complete system, including electronic devices, other components and network infrastructure, using a multi-criteria impact evaluation. The later issue is problematic considering that ISO 14042 recommends using a multi-criteria approach during the characterization of Life Cycle Impact Assessment. The methodology proposed in this paper applies multi-criteria LCA to assess the impact of the complete M2M system including the telecommunication infrastructure.

To validate methodology, the case of Glass Waste Collection is studied. The study includes the complete M2M service and compares it to the conventional service.

2.2 Methodology for an M2M system

As stated in section 1, an M2M system allows machines to communicate with other machines, or other systems, through a communication network. To help understand our methodology for M2M systems, a typical system is shown in Figure 1. The system sends information from the first machine to the telecom network via a gateway, using the Global System for Mobile Communication (GSM) cellular technology. In the telecom network the information is converted into an internet protocol, such as TCP/IP, and can be fed to a back-end server. From the server, the data is sent to the monitoring facility of the second machine. In that way, a Machine-to-Machine system is created.

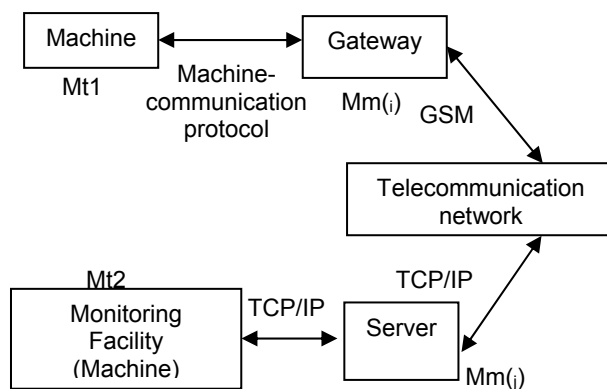

Figure 1: A typical M2M system.

To calculate the environmental impact (EI) of the M2M system, two important contributions must be determined: “equipment” and “communication”.

“Equipment”

This contribution refers to the equipments used by the system. It includes the beginning-machine that could be a sensor or an actuator, the end-machine that could be a desktop or a mobile phone, and the equipment used between the two machines. Material contribution to the environmental impact is determined by summing the impacts of individual equipments as follows:

$$EI_{\text{equipment}} = EI_{M_{t1}} + \sum EI_{M_{m(i)}} + EI_{M_{t2}} \quad (1)$$

With:

- $EI_{\text{equipment}}$: equipment contribution to the environmental impact
- $EI_{M_{t1}}$ and $EI_{M_{t2}}$: respectively, the impacts of the beginning- and end-machines
- $EI_{M_{m(i)}}$: the impact of intermediary equipment i .

“Communication”

Communication covers the communication networks between the machines and the other equipments. It can be divided into two sub-parts.

One sub-part concerns the need for communication directly between machines. A variety of technologies can be used like IEEE wireless, Bluetooth, ZigBee, Wavenis, etc. Concerning environmental issues, this part is related directly to the energy needed to transmit the information. The machines need a power supply that could be the main lines or a battery when access to electric power supplies is not feasible. The environmental impact due to communication directly between the machines is given by:

$$EI_{\text{DCM}} = EI_{\text{elec}} + EI_{\text{battery}} \quad (2)$$

With:

- EI_{DCM} : the impact of Direct Communication between Machines
- EI_{elec} : the impact of electrical energy used to transmit information depends on the wireless technology, the number of times the information is sent each day and the quantity of data
- EI_{battery} : the impact of the battery depends on the battery weight, type and life-cycle.

The battery life-cycle is determined by the transmission protocol, the number of daily emissions, the quantity of data and its capacity. It is derived from initial capacity, self-discharge and daily energy consumption. Initial capacity and self-discharge depend on the technology used. Technologies like Nickel-cadmium, Nickel-metal-hydride, Lead-acid or Lithium-ion are often found in similar applications. These considerations are out of the scope of this paper. The daily energy consumption depends on the wireless technology, the number of daily emissions and the quantity of data. The life cycle of battery is determined by:

$$L_{\text{battery}} = \frac{L_{\text{init}} \times L_{\text{discharge}} \times SF}{E_{\text{normal}} + N \times E_{\text{comm}}} \quad (3)$$

With:

- L_{battery} : the Life span of the battery (days)
- L_{init} : the initial capacity of the battery
- $L_{\text{discharge}}$: the natural self-discharge factor
- SF: Safety Factor
- E_{normal} : the energy consumption during normal use
- N: the number of daily emissions
- E_{comm} : the energy consumption for each emission

The second sub-part is related to communication assumed by the telecom operator. This usually includes GSM, TCP/IP, etc. The contribution to the impact is given by:

$$EI_{\text{oc}} = EI_{\text{send}} + EI_{\text{subscriber}} \quad (4)$$

With:

- E_{OC} : the impact of energy in Operator Communication
- E_{send} : the impact of energy used to transmit data. This depends on the number of daily emissions, and the quantity of data per emission
- $E_{subscriber}$: to calculate the energy contribution of the M2M system for running the telecommunication infrastructure facilities, we assimilate the system to a typical telecommunication subscriber. In the same way that each subscriber is responsible for a fraction of total energy required to run the facilities, we can deduct the share of energy for the M2M system. In that way, $E_{subscriber}$ depends on network energy requirements and the number of subscribers. This energy includes energy for data centres, buildings and other facilities.

It should be underlined that Equation (4) is an important contribution of the paper as environmental impacts of infrastructures are not taken into account in previous studies (see Section 2.1).

To summarise, we suggest that the impact of the M2M service be determined as follows:

$$E_{M2M} = E_{equipment} + \{ E_{DCM} + E_{OC} \} \quad (5)$$

$E_{equipment}$, E_{DCM} and E_{OC} are determined by (1), (2) and (4).

3 CASE STUDY: SERVICE, SCOPE AND MODEL

3.1 Context

Why add a M2M-based PSS to glass waste collection?

A Collection of Glass Waste from bottle banks using PSS based on M2M wireless sensor networks had been tested in 2006 by Orange Labs in Voiron, close to Grenoble, France [12]. The area concerned covers urban and sub-urban sites and serves a population of around 42,000 inhabitants.

Before the introduction of the new PSS, the truck driver of the local waste collection centre had to systematically go to each waste bank, stop the truck and check the level of glass in each container before deciding whether to empty the container or not.

With M2M, sensors are placed inside the containers and measure the level of waste glass. This data can then be used to calculate an optimal collect plan so that the truck driver only goes to and empties the containers that are necessary. Analysis of the PSS by Orange Labs identified possible societal benefits: diminished fuel consumption for the truck; time-saving; noise-reduction; population satisfaction and improvement of traffic circulation.

Supply energy considerations

Glass waste banks are situated on the kerb where there is no access to electric power supplies, furthermore the containers have to be moved every time they are emptied and wired supplies are not possible. Therefore a battery supply is used. In order to insure a sufficient life-span for the battery, power consumption has to be kept low. Since most of the power is used for communication with the gateway, the choice of the communication technology is important. Wavenis Wireless Technology [13] was chosen for its ultra-low-power consumption; high link budget and capacity for long-range connection. Wavenis Wireless is a 2-way wireless connectivity platform dedicated to M2M applications. The PSS model is presented in Figure 2.

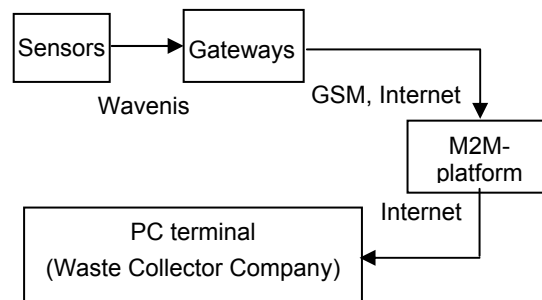

Figure 2: Structure of the M2M-based PSS.

3.2 Scope of the LCA

Since a reduced environmental impact could be a major commercial argument for services, an in-depth environmental impact study has been initiated. LCA methodology is used to answer the questions “Is the proposed M2M service more environment-friendly than the conventional service?” and “What are the major hot spots of the service and how can we improve them?”

The functional unit used for the LCA is: “collect glass waste in the Voiron district during ten years.”

The study uses data from the M2M experimentation conducted between June and September 2006 and comparison with conventional waste collection.

The LCA includes a cradle-to-grave analysis of life-cycle stages: from raw material extraction and acquisition, material processing, product manufacturing, transportation, product use to end-of-life disposal. The environmental impact of the installation of the service is also included. A summary of the elements taken into account is presented in Table 3.

Element	Description	Reference flows considered in the Life Cycle Inventory [Unit Process]	Life Cycle Stages
Sensor	Sensors are installed inside waste containers to measure the glass filling level	Electronic components, battery, printed circuit board and processes, casing, etc [Equipment and Energy]	Transportation, fabrication, use
Wavenis	Communication	Null (Energy is supplied by battery in the sensors and gateways)	No effect
Gateway	Gateways are installed on telephone poles, electricity poles, walls of public buildings	Electronic components, battery, photovoltaic panel, printed circuit board and processing, casing, etc [Equipment and Energy]	Transportation, fabrication, use
Mobile network (GSM)	GSM is used for communication between gateway and M2M platform	Communication, Infrastructure facilities [Energy]	Use + Infrastructure
Internet network	IP network is used to transfer the information on glass filling level of each sensor from M2M platform to waste collection company	Communication, Infrastructure facilities [Energy]	Use + Infrastructure
M2M platform	Server, air conditioning for the server, and material to support the server	Server and air cooling [Energy] Supporting rack [Equipment]	Transportation, fabrication, use
Internet network	The IP network is used to transfer the information on glass level from each sensor from the M2M platform to the waste collect company	Communication, Infrastructure facilities [Energy]	Use + Infrastructure
PC terminal	At the waste company, the middle manager uses a PC to connect to the IP network. With the information from the sensors, he is able to optimize the collect rounds	PC [Energy]	Transportation, fabrication, use
Service installation	The provider is based in Montpellier (France) and must go to Voiron to install the system	Transport, investigation and installation of sensors and gateways [Fuel]	Transportation, for study and installation

Table 3: Elements of the system used in LCA.

- Sensor and gateway: Electronic components, printed circuit board and processes, casing, etc.
- Wavenis: Communication between the sensor and the gateway. The sensor battery supplies the energy needed for this communication and there is no extra energy needed.
- Mobile and internet networks: Communication between the gateway and the M2M platform. Only data for energy in the network was available from Orange. It includes energy used to transmit the information, E_{send} , and energy used to run the operator facilities, $E_{\text{subscriber}}$.
- M2M platform: Server, supporting rack and air cooling. Energy for air cooling is supposed to be the same as for the use of the server. Due to lack of data, only energy in the fabrication and use phases is accounted for [14]. The server in the M2M platform is taken to be HP ProLiant ML350 [15].
- Internet: Energy used to send the information from the M2M platform to the waste collect company via the IP network. It includes energy used to transmit information, E_{send} , and energy used to run the facilities, $E_{\text{subscriber}}$.
- PC terminal: As with the server used in the M2M platform. Only energy in the fabrication and use phases is accounted for [16].
- Transportation: Sensors, gateways, servers and PC terminals. They require transport from their respective manufacturing sites to the installation site. This includes transoceanic freight transport from China to the harbour in the south of France, followed by overland transport by trucks to Voiron.
- Installation: Includes transport to Voiron to study where to place the gateways, and the installation of the sensors and gateways. It does not include the energy and material for installation, due to the unavailability of data.

4 RESULTS

4.1 Choice of impact categories

The case study adopted a multi-criteria approach as recommended by ISO 14042. LCA was performed using EIME LCA software. All the indicators of the Life Cycle Impact categories in the software were accounted for: Natural Resources Depletion (RMD), Energy Depletion (ED), Water Depletion (WD), Global Warming Potential (GWP), Stratospheric Ozone Depletion Potential (ODP), Air Toxicity Indicator (AT), Water Toxicity (WT), Photochemical Ozone Creation (POC), Air Acidification Potential (AA), Water Eutrophication (WE) and Hazardous Waste Production (HWP) [17][17]. However, it is not easy to discuss LCA results considering eleven indicators. In this paper, results are presented for a limited number of indicators, chosen according to Orange Labs' policy and their relevance in the context of M2M services, namely:

- ED (expressed in MJ): represents energy contents in materials and the consumption of energy. It is important for running services. Furthermore, as stated before, the only data available on the server, PC terminal and telecommunication networks are expressed only in terms of electrical power consumption.
- GW (expressed in g eq. CO₂): that represents global warming expressed as the equivalent CO₂ contribution to the greenhouse effect. This is a very important global issue today and could not be omitted.
- AT (expressed m³) and WT (expressed dm³): that represent toxicity in air and water; they correspond to the air/water volumes necessary to dilute contaminated air/water, respectively. They were chosen because they represent toxicity in a human environment. This is especially important for services deployed in the city.
- RMD (expressed in year-1): that is the depletion of natural resources, for which gold, silver and copper are major contributors. These rare materials are used a lot in electronic devices which are major components of the M2M system.

These impact categories are typical for LCA of electr(on)ic devices. Sanitary impacts of electromagnetic waves are not considered in this study.

4.2 Major contributors to environmental impacts

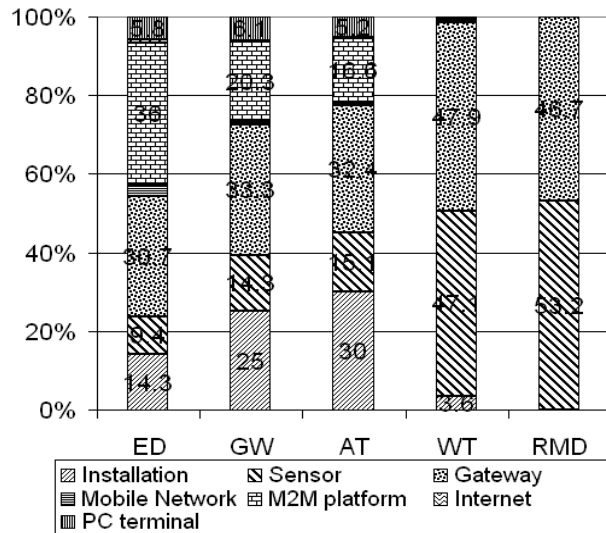

Figure 3: Comparative impacts of each component for five environmental criteria.

The study considers environmental impacts of the following life cycle stages: material extraction; manufacturing; distribution; and use. Performances of end-of-life treatment are not covered.

Figure 3 shows the relative contribution for each component of the service using the 5 preselected indicators.

The comparison calls for some remarks:

- The gateway is the major contributor to most of the impacts. This appears for all the indicators: GW (33.3%), AT (32.4%), WT (47.9%) and RMD (46.7%). For ED, gateway represents the second impact (30.7%). This results from the use of electronic components, the battery and the photovoltaic panel and a relatively large casing. The share of the different components of the gateway is shown in Figure 4.

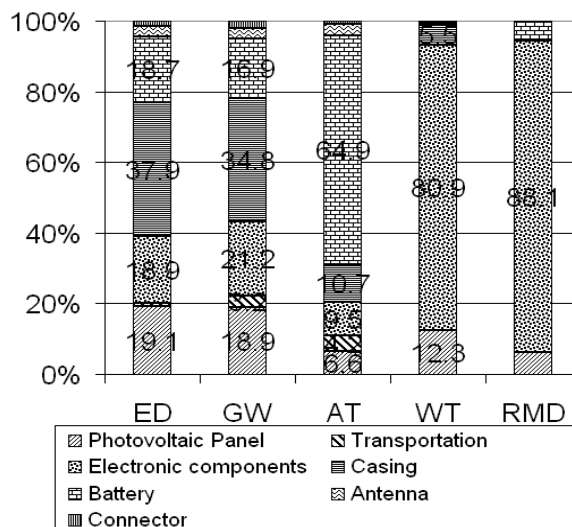

Figure 4: Comparative impacts of each part in gateway.

- The M2M platform is the highest contributor for ED and is important for GW and AT, but disappears for the other indicators. This is due to the fact that only energy for the server fabrication is taken into account. It is probable that taking

into account all reference flows (including materials and processes) would increase the importance of its contribution to the other indicators. This remark is also true for the PC terminal.

- Two indicators of WT and RMD are most affected by the gateway and the sensor. This is caused by the electronic components. Material for fabricating and processing electronic components and printed circuit boards, for instance, gold, silver and copper are major contributors for WT and RMD. As explained above, although the M2M platform and PC terminal contain a lot of electronic components they do not affect these indicators because only the energy for fabrication and use was taken into account.
- It can be noted that an analysis based on just one criterion is not sufficient to interpret the results and multi-criteria reveals some important points. Leaving aside the components for which only energy was inventoried (M2M, telecommunication ...), a comparison between the gateway and the sensor is interesting. The gateway is the most impacting factor for ED, GW and AT, whereas the results change significantly for the other two indicators. This point is due to the type of power supply in the two cases. The sensor is battery-run while the gateway resorts to solar energy and photovoltaic cells. Different technologies behave differently from an environmental point of view.
- Installation plays a key role in ED, GW and AT due to the fuel consumption for transport.
- For the mobile network and internet infrastructures, the remarks concerning ED and the other impacts for the M2M platform remains true, contributions appear in ED, GW and AT, but disappear in WT and RMD because only energy is taken into account and the electronic devices of the network are not accounted for. In addition, even for ED their contributions can be ignored due to their relatively small values. This is because the quantity of information sent to the service platform is very small, only 120 bytes per message are necessary. Furthermore the information is sent only once a day. However their relative impacts could well change if the number of daily emissions is increased. This new hypothesis merits to be studied in more detail.

4.3 Influence of the number of daily emissions

This section will study what will happen if the number of emissions is increased to 24 times per day. Although such a hypothesis is quite unrealistic for waste collection (unless the municipal council could require that the levels be measured once an hour to avoid overfilling), such frequencies are quite possible for other M2M services. However, in this case, care must be taken to anticipate the technological modifications to the system in order to do so. The important changes are studied as follows.

Sensor Battery

For the sensor, as the energy consumed during the emissions is increased, the life cycle of its battery is reduced. The life span of the battery is determined by the daily energy consumption of the sensor. Table 4 presents the energy consumption in the normal and communication modes.

Mode	Consumption (mAs per day)
Normal mode	
Standby	260
Inquiry mode	80
Micro-processor	10
Total for normal mode	350
Communication mode	
Emission	110
Micro-processor	10
Other protocols	80
Total for communication mode	200

Table 4: Energy required for sending data.

According to formula (3), the life span of the battery is dependant on the communication protocol and the number of daily emissions.

Number of daily emissions	Consumption (mAs per day)	Life cycle of battery (year)
1	550	17
12	2800	4.9
24	5100	2.6

Table 5: Battery life span.

The battery used in the sensor is a Li-SoCl₂ battery rated as 2250 MAh. The self-discharge of battery is dependent on factors like the type of battery, humidity, temperature, etc. In this case, the self-discharge is estimated as 40%. A safety factor of 70% is taken to calculate battery life. The resulting life span is shown in Table 5 for different numbers of daily emissions.

Although the estimated life span of the battery with one emission per day is 17 years, for practical reasons usage is limited to 10 years. Beyond this limit, operation may not be insured under harsh conditions of humidity, temperature and mechanical vibrations. In the case of 24 emissions per day, the life cycle of battery is 2.6 years, and four batteries must be used to attain the functional unit. Due to the greater number of batteries, the casing of the sensor must be larger, and its weight

recalculated: it is now considered 30% larger than the original one. Modifications to the transportation of the sensor are taken into account in this case.

Gateway battery and photovoltaic panel

A photovoltaic panel and a rechargeable battery are used for power supply. Energy from the photovoltaic panel and its environmental impacts are reviewed in [18-19]. For the new system, to ensure sufficient power supply in the gateway, the sizes of the photovoltaic panel and the rechargeable battery must be increased. To calculate the required sizes, the daily energy consumption of the gateway must be determined. This energy includes two parts, communication with the sensor and GSM-communication with the telecommunication infrastructure. The first part is has similar energy-consumption to the sensor presented in Table 4, because the electronics is the same. The energy used for GSM-communication is presented in Table 6. This table takes into account that an emission requires connection, sending information, and de-connection.

Mode	Consumption (mA.s per day)
Standby	110000
Connection	600
De-connection	300
Emission	700
Total	110000

Table 6: Energy requirements for GSM.

The daily consumption of the gateway depends on the number of emissions and is shown in Table 7. The third column of the table shows the ratio of the photovoltaic panel and battery sizes for moving from 1 emission per day to N emissions per day. For the new scenario of 24 emissions per day, the sizes of the photovoltaic panel and the battery are increased by a factor of 1.4. The size of gateway casing and transport parameters must be changed accordingly.

Number of daily emissions (N)	Consumption (mAs) per day	Energy ratio: N emissions/day to 1 emission/day
1	110000	1
12	130000	1.2
24	150000	1.4

Table 7: Ratio of energy consumption.

Mobile network

The impact for operator communication is changed as follows:

$$EI_{OC} = 24 \times EI_{send} + EI_{subscriber} \quad (6)$$

This equation is true for the mobile network and for the internet.

Result

The result of the relative environmental impacts of each component is presented in Figure 5.

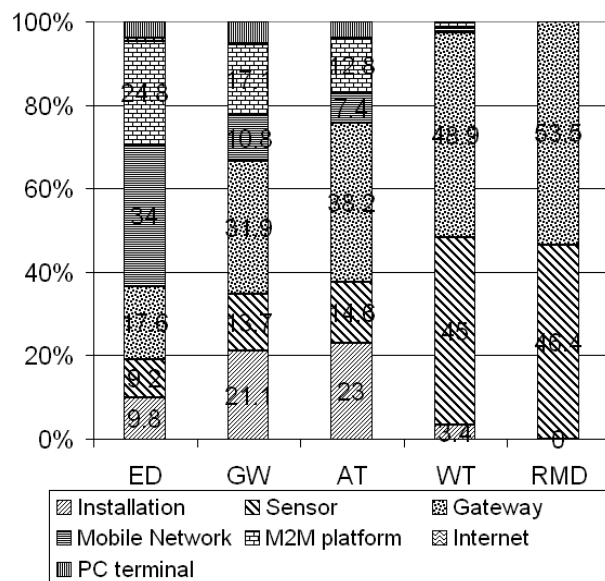

Figure 5: Environmental impact of components with 24 emissions per day.

The impacts of the mobile network and internet increase for ED, GW, and AT when compared with one emission per day. Even though the casings, batteries, photovoltaic panel and transport increase for the gateways and sensors, the relative increases in energy for the two networks are much larger. This means that in LCA for M2M services the impact of the infrastructure must indeed be taken into account.

4.4 Comparison between the M2M service and the conventional service

As stated in section 3, using the M2M service for the glass waste collection can provide important gains in fuel consumption for the truck.

Gains were estimated during the experimentation over a 12 month period. Observation of glass waste collection trips with the truck driver enabled an estimation of the time and distance gains for each round trip. The driver can avoid containers are filled to less than 60% of their volume. The distance gains in city areas are estimated to be between 20%-37% and in small villages between 25%-32%. If the critical level of glass is set of 70% instead of 60%, the distance gains can attain 22%-41% in the city and 25%-32% in small villages. In this section, a critical level of 60% is considered. Average distance gains in the city are 28% and in small villages, 28%.

The comparison of environmental burdens of the M2M and conventional services is made by comparing the burdens of the M2M service to the truck gains using this service. Figure 6 presents the results.

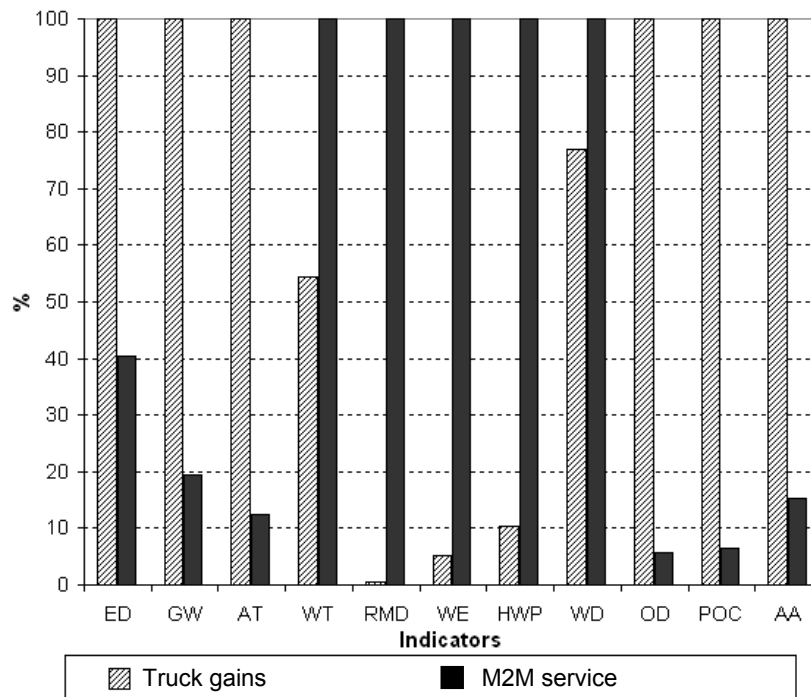

Figure 6: Comparison of environmental impacts of the M2M service and the truck gains (normalized indicators).

For RMD, WD, WT, WE, and HWP, the M2M service shows a greater impact than the conventional service, and improves the other indicators (ED, GW, AT, OD, POC and AA). In order to deploy and sell the M2M service, the service must be improved and the incriminated environmental impacts reduced. Section 4.2 shows that to do this efficiently, efforts should be concentrated on the gateway and the sensors, and in particular, their energy supplies must be improved.

5 CONCLUSION

This paper presents a life-cycle assessment (LCA) of an M2M-based PSS. To access the environmental impact of the PSS, a proposed methodology that takes into account a complete system is presented. This methodology is applied for the case study of a service deployed and tested by Orange Labs in Voiron, France. The LCA shows that using the M2M service for Glass Waste Collection applications has the potential to achieve environmental benefits in comparison to conventional glass waste collection services. It reveals the weak points. Our proposed methodology and results for the case study show that the ICT infrastructure must be taken into account. Multi-criteria approach must be used to identify the major contributors of the service. This will show where design efforts should be concentrated.

Future work should include a full inventory of the servers and PCs including the material to show their effects on the RMD and WT indicators. Influence of the size of the messages and the types of battery could also be studied.

6 ACKNOWLEDGEMENTS

The authors would like to thank the personnel from Orange Labs for have helped at various points in this work: Pierre Brouquet, Pascal Cerruti, Jean-Claude Merle in the inventory of the electronic devices; special thanks to Michel Remy for calculations on energy supplies; and Madhusudan Giyyarpuram for his valuable discussions on M2M systems.

The experimentation in Voiron would not have been possible without the help of the Communauté d'Agglomérations du Pays Voironnais (CAPV). Many thanks to the CAPV personnel, namely, Jean-Marc Bouzon and Romain Chatel, and to the unities of Orange who helped installing the gateways. From Orange Labs, it was René Ebel who created the technical part of the experimentation.

7 REFERENCE

- [1] Lawton, G., 2004, Industry Trends, Machine-to-Machine Technology Gears Up for Growth, *IEEE Computer Society*: 12-15.
- [2] Rebitzer, G., Ekvall, T., Frischknecht, R., Hunkeler, D., Norris, G., Rydberg, T., Schmidt, W., Suh, S., Weidema, B., Pennington D., 2004, Life cycle assessment Part 1: Framework, goal and scope definition, inventory analysis, and applications, *Environment International*, Elsevier, 30: 701-720.
- [3] Pennington, D., Potting, J., Finnveden, G., Lindeijer, E., Jolliet, O., Rydberg, T., Rebitzer, G., 2004, Life cycle assessment Part 2: Current impact assessment practice, *Environment International*, Elsevier, 30: 721-739.
- [4] Millet, D., Bistagnino, L., Lanzavecchia, C., Camous, R., Poldma, T., 2007, Does the potential of the use of LCA match the design team needs?, *Journal of Cleaner Production*, 15: 335-346.
- [5] Taiariol, F., Fea, P., Papuzza, C., Ramella, A., 2001, Environmental impact of a telecommunication service, *IEEE International Symposium on Electronics and the Environment*, May: 273 – 278.
- [6] Loenrincik, Y., Sangwon, S., Jolliet, O., 2003, Life Cycle Environmental Impact of the Internet infrastructure in a University, *IEEE International Symposium on Electronics and the Environment*, 19-22 May: 173-176.
- [7] Takahashi, K.I., Tatemichi, H., Tanaka, T., Nishi, S., Kunioka, T., 2004, Environmental Impact of Information and Communication Technologies Including Rebound Effects, *IEEE International Symposium on Electronics and the Environment*, 10-13 May: 13-16.
- [8] Moberg, A., Johansson, M., Finnveden, G., Jonsson, A., 2007, Screening environmental life cycle assessment of printed, web based and tablet e-paper newspaper, *Reports from the KTH Centre for Sustainable Communications*, ISSN 1654-479X, Stockholm
- [9] Dubberley, M., Agogino, M., 2004, Life-cycle assessment of an Intelligent Lighting System Using a Distributed Wireless Mote Network, *IEEE International Symposium on Electronics and the Environment*, 10-13 May: 122-127.
- [10] Demeester, P., 2008, Energy Efficient Communication, *ICT-MobileSummit 2008*, 10 - 12 June 2008, Stockholm, Sweden
- [11] Souchon, L., 2008, TIC et Énergétique: Techniques d'estimation de consommation sur la hauteur, la structure et l'évolution de l'impact des TIC en France, *Thèse de doctorat de l'Institut National des Telecommunications*.
- [12] Graindorge J., 2007, Vers des tournées de collect programmées juste à temps, *Dialogues* No. 38: 7
- [13] Wavenis Technology Overview, 2009, www.coronis.com/en/wavenis_technology.html
- [14] Williams, E., 2004, Revisiting energy used to manufacture a desktop computer: hybrid analysis combining process and economic input-output methods, *IEEE International Symposium on Electronics and the Environment*, 10-13 May: 80-85.
- [15] *Quick Specs - HP ProLiant ML350*, 2009.
- [16] Socolof, M.L., Overly, J.G., Kincaid, L.E., Dhingra, R., Singh, D., Hart, K.M., 2001, Life-Cycle Environmental Impacts of CRT and LCD Desktop Monitors, *IEEE International Symposium on Electronics and the Environment*, 7-9 May: 119-127.
- [17] *EIME Indicators Manual*, 2009, www.codde.fr
- [18] Stoppato, A., 2008, Life cycle assessment of photovoltaic electricity generation, *Journal of Energy* 33: 224-232.
- [19] Alsema, A., Frankl, P., Kato, K., 1998, Energy Pay Back Time of PV Energy System: Present status and prospects, *2nd Conference on PV Solar Energy Conversion*, 6-10 July: 2125-2130.